

Adjacent cabinets and components should be assembled by fastening through the interior panels with the screws or bolts provided. Tighten securely.

Mirrors are provided with mirror clips and wood screws. Attach one mirror clip at each corner approximately 2" in from the vertical edge.

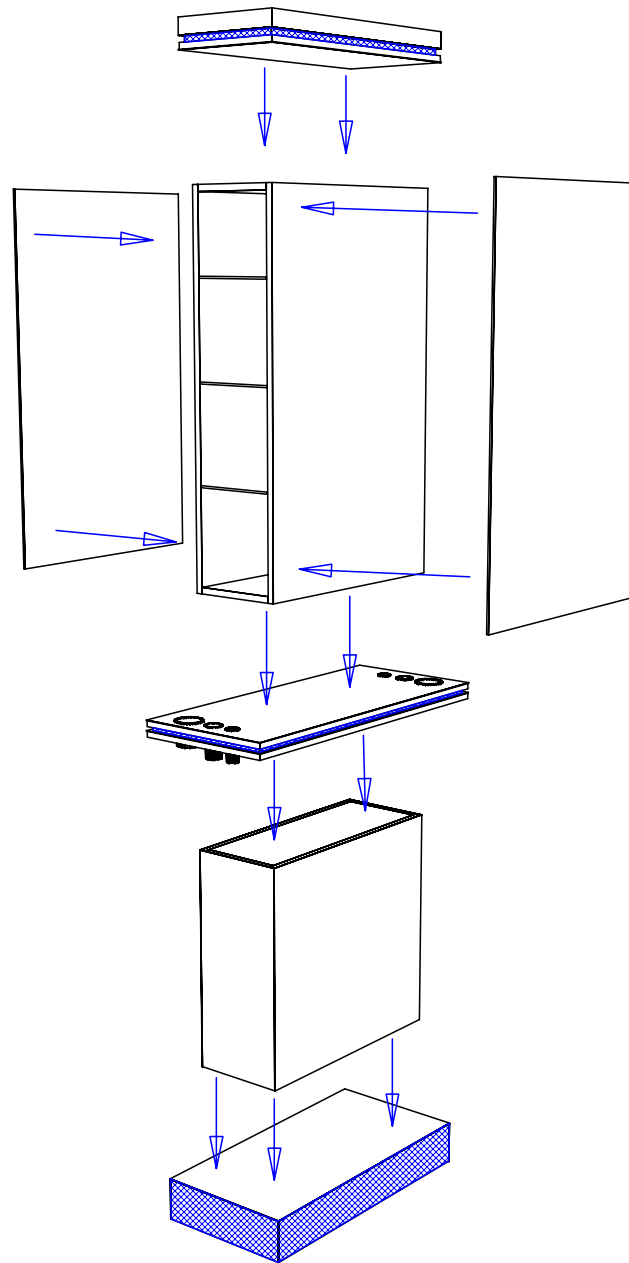

Finish Schedule -

Face Color -
 Top Color -
 Toe Color -
 Pulls -
 Interior -
 Other (Specify) -

General Notes:

1. All counter tops are to be made removable wherever possible.
2. Items must be broken into manageable sections For Shipping. Mark For Ease Of Reassembly.
3. Install Shipping Cleats Wherever Possible To Prevent Shipping Damage.
4. Purchased items Must Be Trial Fit Before Shipping.

 Collins Manufacturing
 2000 Bowser Rd.
 Cookeville TN 38506

Title: 440-42 QSEp Captiva Styling Island

Size: # Drawn By:

Date: Sheet #: 7

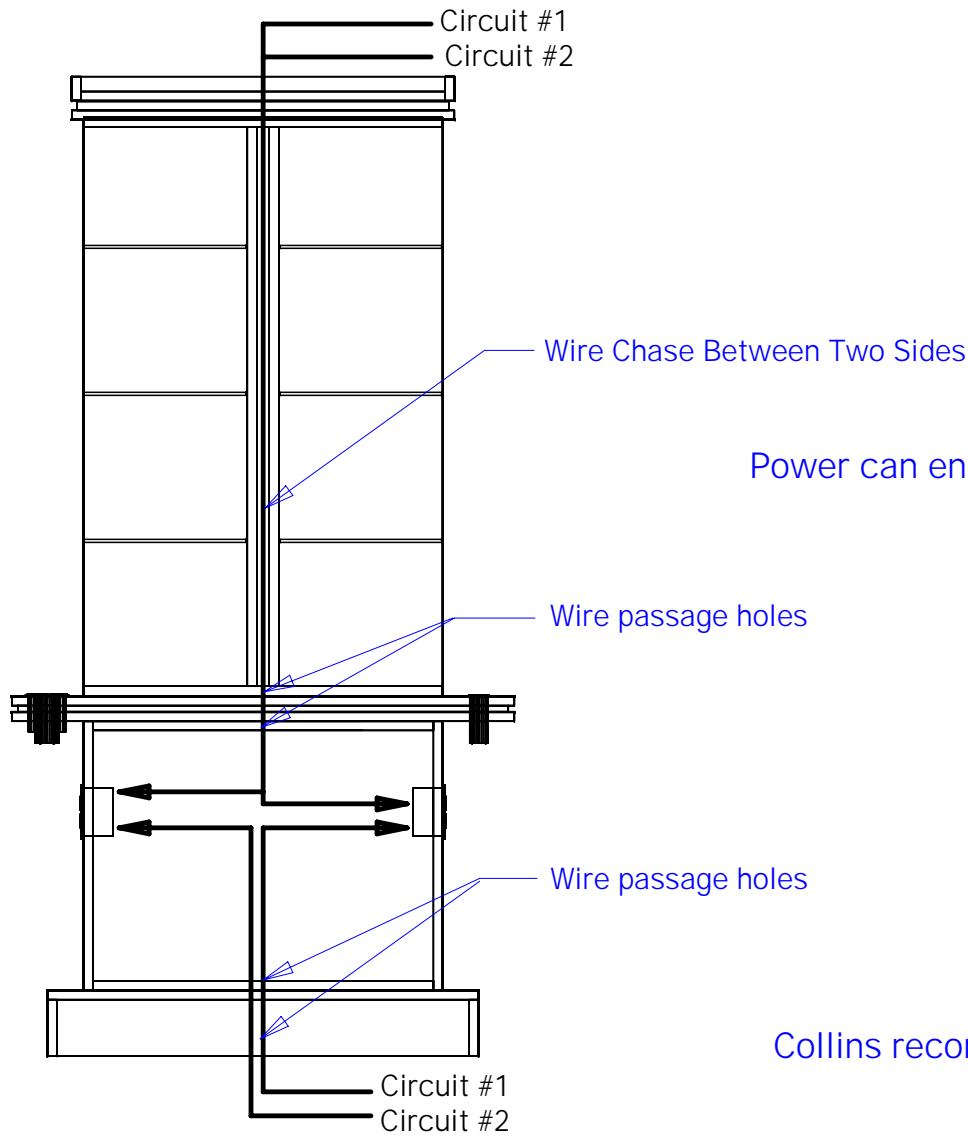

Power can enter the station from the floor or from the ceiling.

Collins recommends a 110 volt - 20 amp circuit per stylist.

Quantity -

Finish Schedule -

Face Color -
 Top Color -
 Toe Color - (Specify)
 Pulls -
 Interior -
 Other (Specify) -

General Notes:

1. All counter tops are to be made removable wherever possible.
2. Items must be broken into manageable sections For Shipping. Mark For Ease Of Reassembly.
3. Install Shipping Cleats Wherever Possible To Prevent Shipping Damage.
4. Purchased items Must Be Trial Fit Before Shipping.

 Collins Manufacturing 2000 Bowser Rd. Cookeville TN 38506		
Title: 440-42 QSEp Captiva Styling Island		
Size:	#:	Drawn By:
Date: 03/31/06	Sheet #: 8	