

1. Remove drawers (see illustration) to allow access to interior of base cabinet. Place Upper display on top of base cabinet and bolt through interior top of base into the factory installed threaded inserts in bottom of display. Use the 8 provided bolts.
2. Attach unit to wall with the provided 3" wood screws making sure to hit wall studs.
3. Set crown cap in place and secure to cabinet by screwing through cap into top of display with the provided 1 1/2" wood screws. Reinstall drawers.

Eyeball light fixtures are provided with a 2' cord. The electrician is responsible for providing an outlet for the light fixture to plug into. Bulbs are 25w - reflector type.

All electrical work is to be performed by a licensed electrical contractor and to be performed in accordance with all applicable national, state, and local codes.

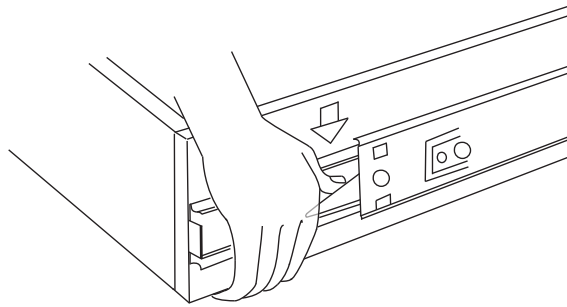

- To Remove Drawer**
 Pull the drawer fully open so levers are visible.
 Push "down" on the right lever (shown), and "up" on the left lever.
 Holding levers in place, pull drawer toward you.
- To Reinsert Drawer**
 Bring ball retainer fully forward and carefully reinsert drawer member slide into the cabinet member slide, guiding the drawer member raceway between the ball bearings.
 Completely close drawer.
 Open and close drawer to ensure the slide is fully engaged into the ball bearing track.

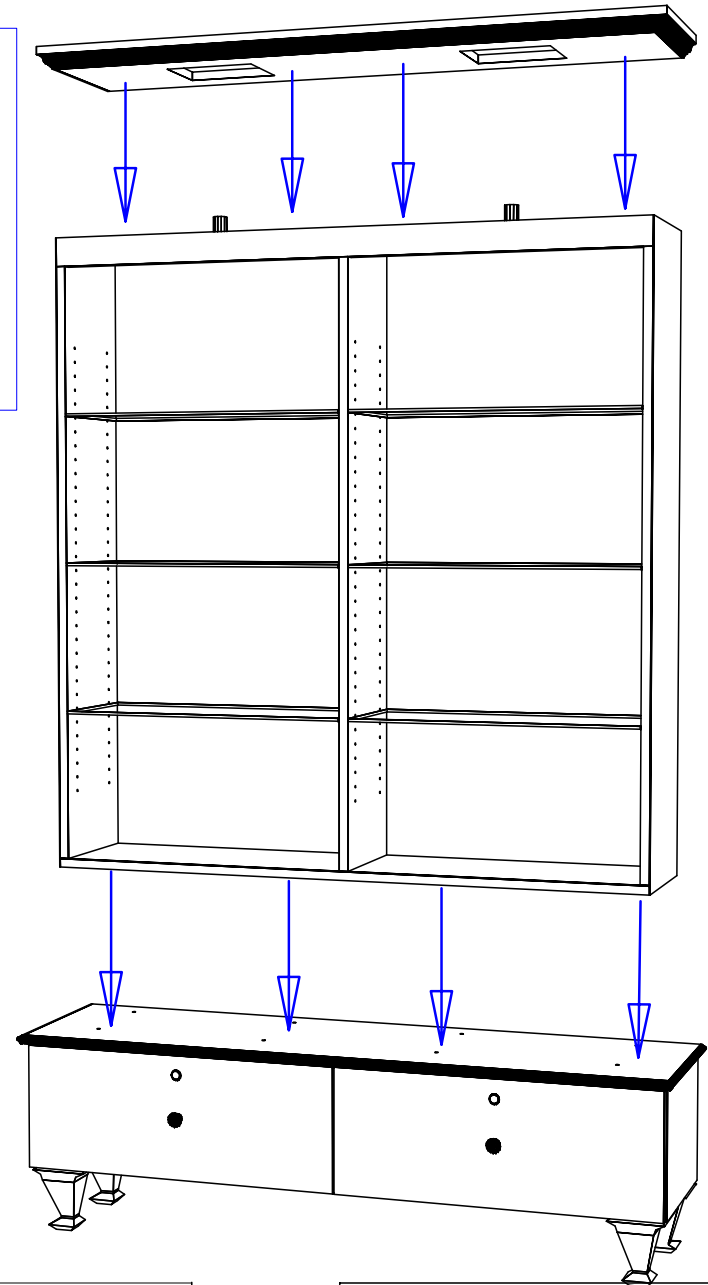

Quantity -

Finish Schedule - 908-60-1

Face Color -
 Top Color -
 Toe Color -
 Reveal / Accent Color -
 Hardware -
 Interior -
 Other (Specify) -

General Notes:

1. All counter tops are to be made removable wherever possible.
2. Items must be broken into manageable sections For Shipping. Mark For Ease Of Reassembly.
3. Install Shipping Cleats Wherever Possible To Prevent Shipping Damage.
4. Purchased items Must Be Trial Fit Before Shipping.

		Collins Manufacturing 2000 Bowser Road Cookeville, TN 38506	
Title:			
Size: NTS	Drawing Number: Job	Drawn By:	
Date: 12/05/07	Sheet		5 of 5