

Quantity -

Finish Schedule -

- Face Color -
- Top Color -
- Toe Color -
- Pulls -
- Interior -
- Other (Specify) -

Collins Manufacturing
 2000 Bowser Road
 Cookeville TN 38506

Customer: Project Name		
Scale: Scale	Order:	Drawn By: Drawn By
Date: Month Date, Year	Sheet:	Sheet #

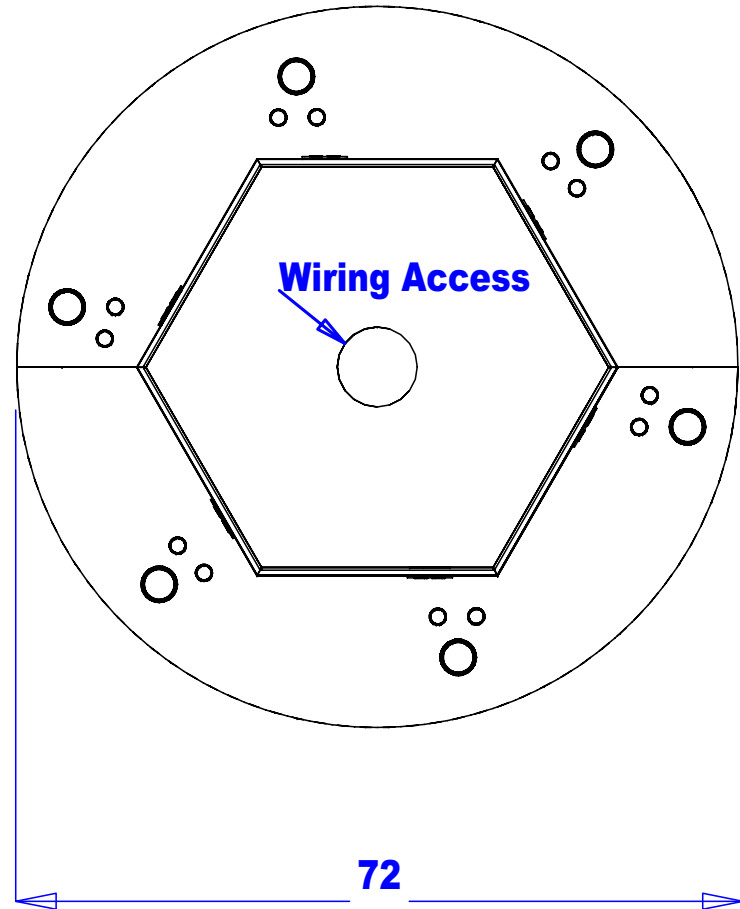
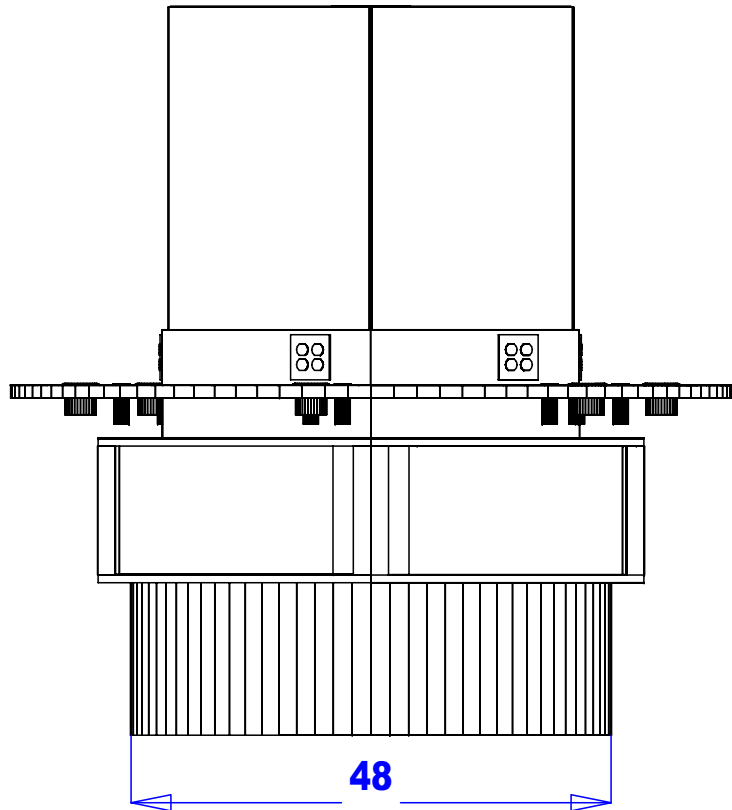

Finish Schedule - So32991-3

Face Color -
 Top Color -
 Base Color -
 Pulls - N/A
 Interior -
 Other (Specify) -

General Notes:

1. All counter tops are to be made removable wherever possible.
2. Items must be broken into manageable sections For Shipping. Mark For Ease Of Reassembly.
3. Install Shipping Cleats Wherever Possible To Prevent Shipping Damage.
4. Purchased items Must Be Trial Fit Before Shipping.

Collins Collins Manufacturing
 2000 Bowser Rd.
 Cookeville TN 38506

Title: **32991.3 Detail**

Size:	# 62786	Drawn By: ben
Date:	Sheet #: 1	

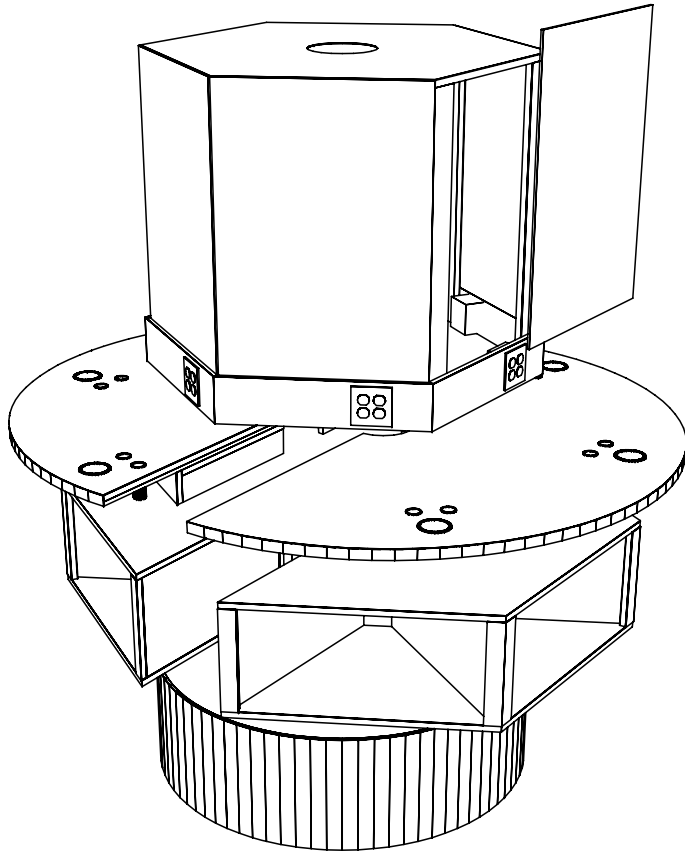

Adjacent cabinets and components should be assembled by fastening through the interior panels with the screws or bolts provided. Tighten securely.

Cabinets are marked for ease of assembly. Match up like markings for both vertical and horizontal sections. Markings will be on the backs or other surfaces that are inconspicuous after installation.

Duplex and quad outlets are provided with 15 amp grounded receptacles. Electrician should provide power supply and connect to receptacles per local and national electric codes.

Mirrors are provided with mirror clips and wood screws. Attach one mirror clip at each corner approximately 2" in from the vertical edge.

Finish Schedule - So32991-3

Face Color -
 Top Color -
 Toe Color -
 Pulls - N/A
 Interior -
 Other (Specify) -

Installation Notes:

- 1. All hardware needed for assembly is included.**
- 2. Large items are preassembled at the factory to ensure proper alignment. Items are then disassembled into manageable sections for shipping purposes and ease of reassembly.**
- 3. Shipping cleats need to be removed before installation. These cleats are installed to prevent damage.**

		Collins Manufacturing 2000 Bowser Rd. Cookeville TN 38506	
Title: 32991.3 Assy			
Size:	#: 62786	Drawn By: ben	
Date:			Sheet #: 7