

**Part #:** 5517-48  
**Description:** QSE Standard Table



**Standard Features:**

- 1 full extension drawer
- Storage cabinet w/ adj. shelf
- Black lamp
- Black padded upholstered rest
- Sturdy leg
- Twinwheel casters
- 
- 
- 

*Eight Color Choices: Black, Shaker Cherry, Cafelle, Fusion Maple, Limber Maple Wild Cherry, Brighton Walnut, Graphite Nebula*



*(Forty additional choices available for 10% upcharge)*

**Specifications:**

QSE Standard Table w/ drawer, storage cabinet w/ shelf, double-strong leg, casters, padded upholstered rest, black lamp. 48"W x 20"D x 30"H.

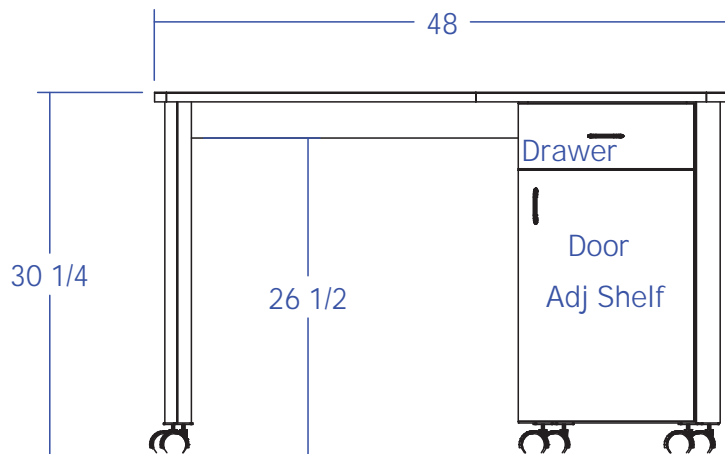

**Optional Features:**

- Cam locks on door & drawer
- 
- 
- 

**Shipping and Assembly/Installation Information**

Assembly Required:	<input checked="" type="checkbox"/> Yes	<input type="checkbox"/> No
Electrical Required:	<input type="checkbox"/> Yes	<input checked="" type="checkbox"/> No
Plumbing Required:	<input type="checkbox"/> Yes	<input checked="" type="checkbox"/> No
Ship Dimensions	32 "W x 60 "D x 40 "H	
Total Ship Weight	146 LBS	
# of Ship Pieces	Cartons 1	Skids

**Additional Information:**

