

**This item includes a six outlet power strip with a 4' cord. The outlet strip is rated at 15 amps. The electrician is responsible for providing and mounting an outlet inside the cabinet for the power strip to plug into. The electrician is also responsible for cutting an appropriate entry point for getting power into the cabinet.**

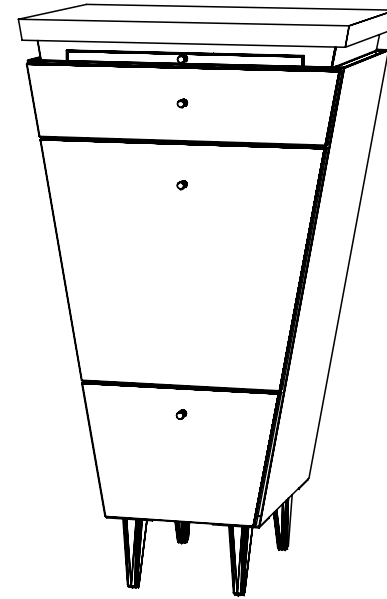
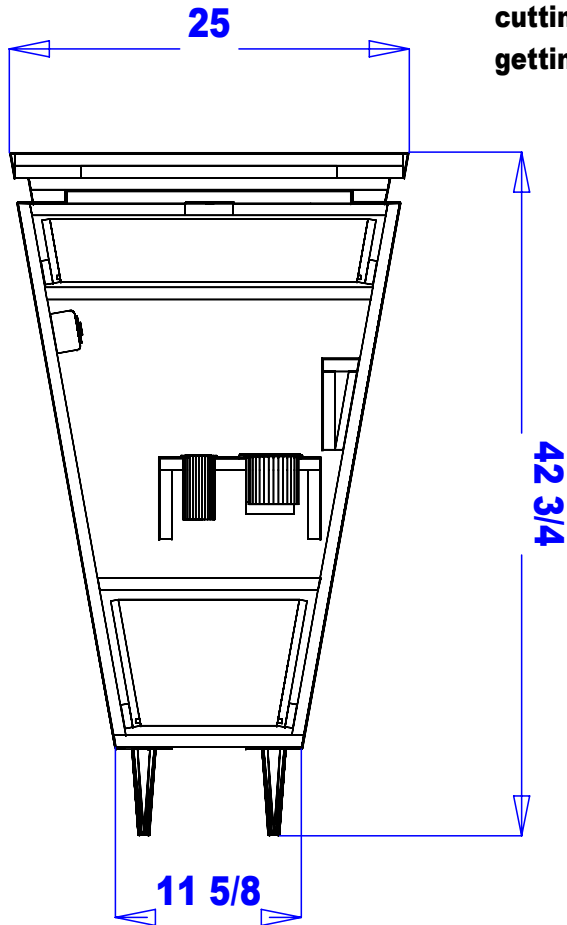

Preliminary  
Not For Construction

This drawing is the property of Collins Manufacturing Company and is protected under copyright law.

**Finish Schedule - 860-24-1**

- Face Color -
- Top Color -
- Toe Color -
- Pulls -
- Interior -
- Other (Specify) -

This drawing represents Collins Manufacturing Company's understanding of the desired item as was previously priced & ordered. Your signature indicates you have reviewed the drawing; and your approval will authorize Collins to initiate the acquisition of materials & subsequent production. More than modest changes may affect the price and/or manufacturing lead time.

- Approved as drawn.
- Approved w/ changes noted.
- Not approved - re-submit.

Signature \_\_\_\_\_  
Company \_\_\_\_\_ Date \_\_\_\_\_

**collins** Collins Manufacturing  
2000 Bowser Rd.  
Cookeville TN 38506

Title: <b>860-24 VANELLE VANITY</b>		
Size:	#:	Drawn By:
Date:	Sheet #:	

1/2" Luan French Cleat

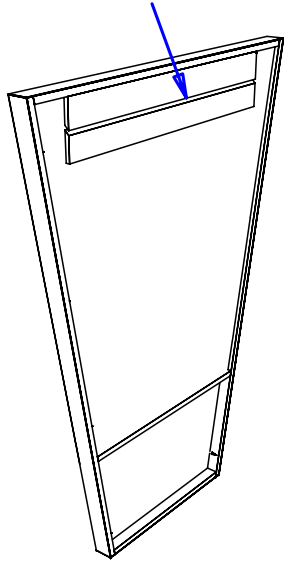

French cleat should be attached to the wall by screwing through the cleat into wall stud or blocking using the fasteners provided. The cleat should be level and at the indicated height.

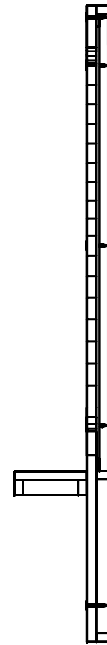
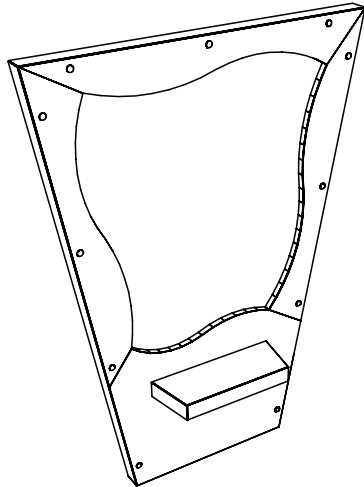

69 3/4" Above Floor (May Be Slightly Higher Or Lower To Meet Customer Preference.)

### Finish Schedule

Face Color -  
Top Color -  
Toe Color -  
Pulls -  
Interior -  
Other (Specify) -

### Installation Notes:

1. All hardware needed for assembly is included.
2. Large items are preassembled at the factory to ensure proper alignment. Items are then disassembled into manageable sections for shipping purposes and ease of reassembly.
3. Shipping cleats need to be removed before installation. These cleats are installed to prevent damage.

**collins**

Collins Manufacturing  
809 E 20th Street  
Cookeville TN 38501

Title: **861-40 VANELLE MIRROR**

Size:

#:

Drawn By:

Mike

Date:

Sheet #: