

ROLLER BALL



Model

AK - S23S

AK - S23SF

# Assembly Instructions

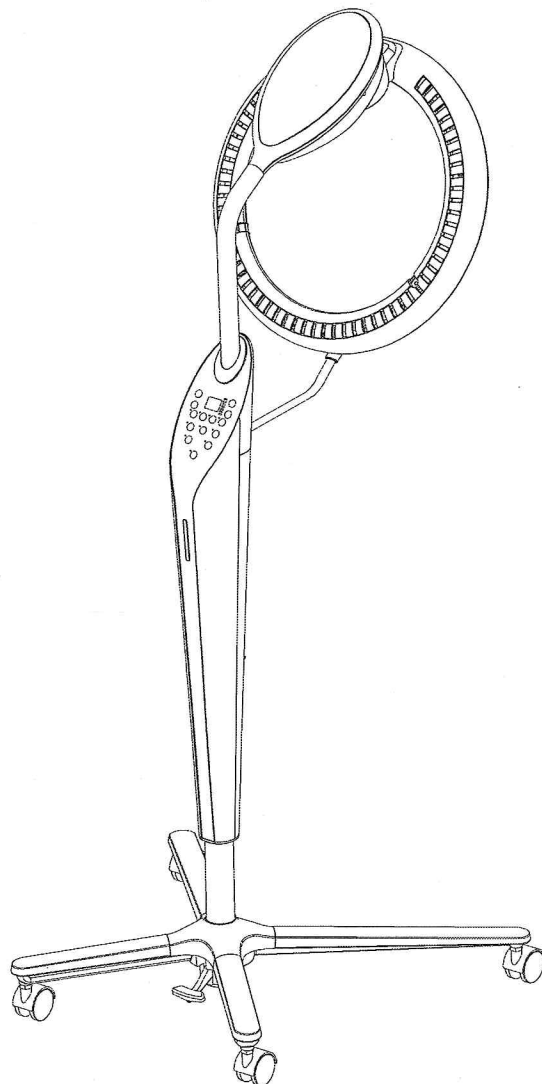

## <Before Assembling the Product>

Check the parts supplied with the product.





Prepare a No.2 Phillips-head screwdriver for assembling.



### CAUTION

Never take out the upper main unit from the carton box or assemble the unit by holding it at the ring.

### 【Screws Supplied】

- M5 x 15 cap bolt (with spring washer) 7 pieces 
- M4 x 12 binding-head screw 2 pieces 
- M4 x 12 (black) binding-head screw 1 piece 
- M3 x 15 pan-head screw (with flat washer, spring washer) 1 piece 

### 【Parts Supplied】

#### Common Parts

- Stand base •••••1 set

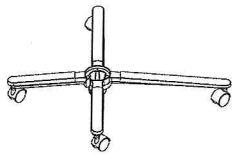

- Stand pole assembly ••1 set

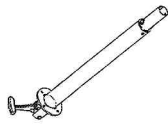

- Stand base cover ••••1 piece



- Guide bar •••••1 set

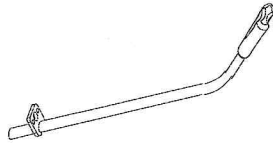

- Upper main unit ••1 set

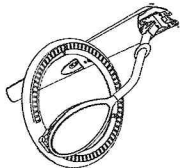

- Power cord ••••1 set

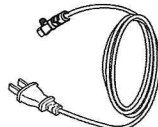

- Allen key wrench ••1 piece
- \*Opposite side: 4 mm

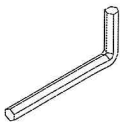

- Power cord stopper ••1 piece



#### Parts supplied depending on purchased specification

##### Specification w/o Fan

- Upper main unit cover •1 set

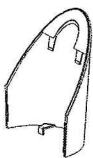

##### Specification w/ Fan

- Upper main unit cover •1 set (with Fan)

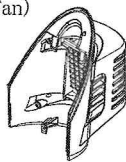

### 【Assembling Procedures】

#### Common Procedures

- Assembling the stand.
- Installing the stand base cover.
- Fixing the upper main unit onto the stand.
- Raising and fixing the shaft.
- Installing the guide bar.

##### Specification w/o Fan

- Installing the upper main unit cover.

##### Specification w/ Fan

- Installing the upper main unit cover (w/ Fan).

#### Common Procedures

- Installing the pipe cover.
- Attaching the power cord.
- Completion.

#### Checking of Operations

• **Assembling the stand.**

\*Tighten the stand pole firmly to prevent the unit from rattling.

M5 x 15 cap bolt : 4 pieces  
(With a spring washer)

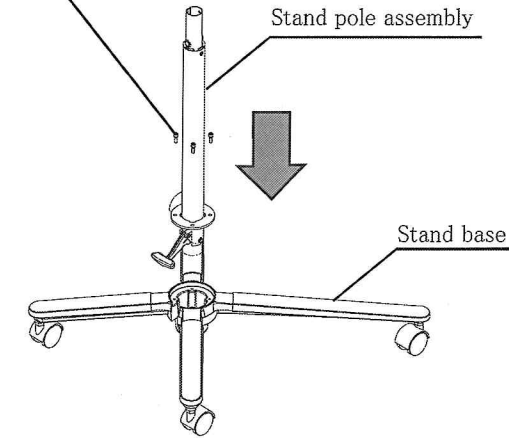

Insert the stand pole into the stand base and tighten at four points with the supplied screws.  
\* Use the supplied L-shaped wrench.

• **Installing the stand base cover.**

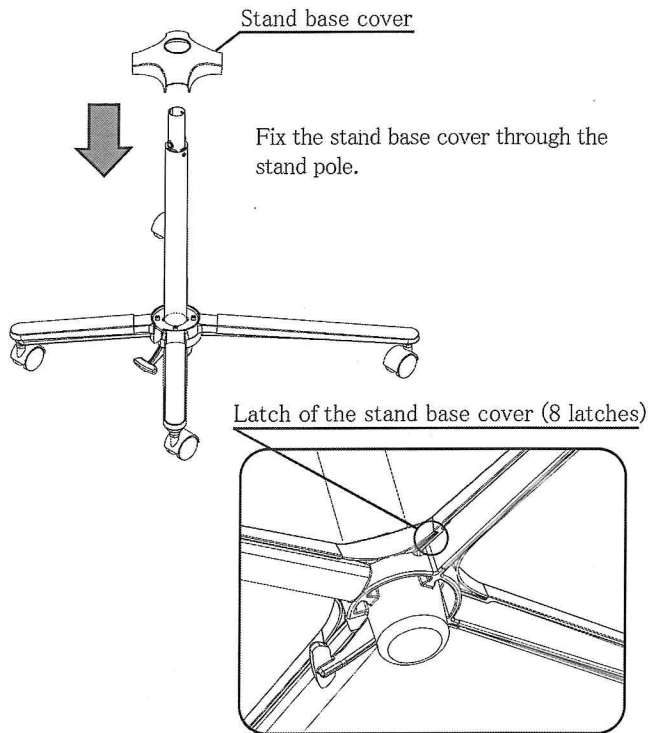

Fix the stand base cover through the stand pole.

\*Install the stand base cover so that the latches on the backside will hook onto the stand base.

• **Fixing the upper main unit onto the stand.**

\*Do not hold the unit at the ring when performing this procedure.

\*Tighten the screws firmly to prevent the unit from rattling.

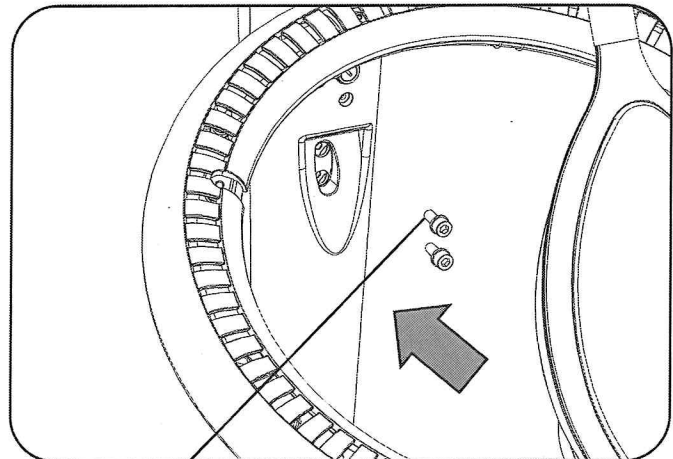
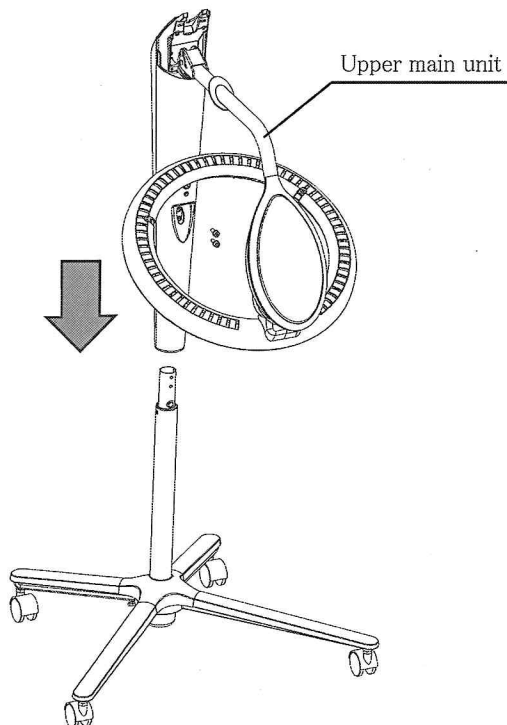

M5 x 15 cap bolt (with spring washer): 2 pieces

Insert the upper main unit into the stand pole, and tighten it at two points with the supplied screws.  
\*Use the supplied L-shaped wrench.



## CAUTION

Never release your hands from the shaft throughout the operation of step. Doing so may cause an impact to the root of the shaft, resulting in a damage of the product.

Dropping the shaft may cause a strong impact that can result in a damage of the product.

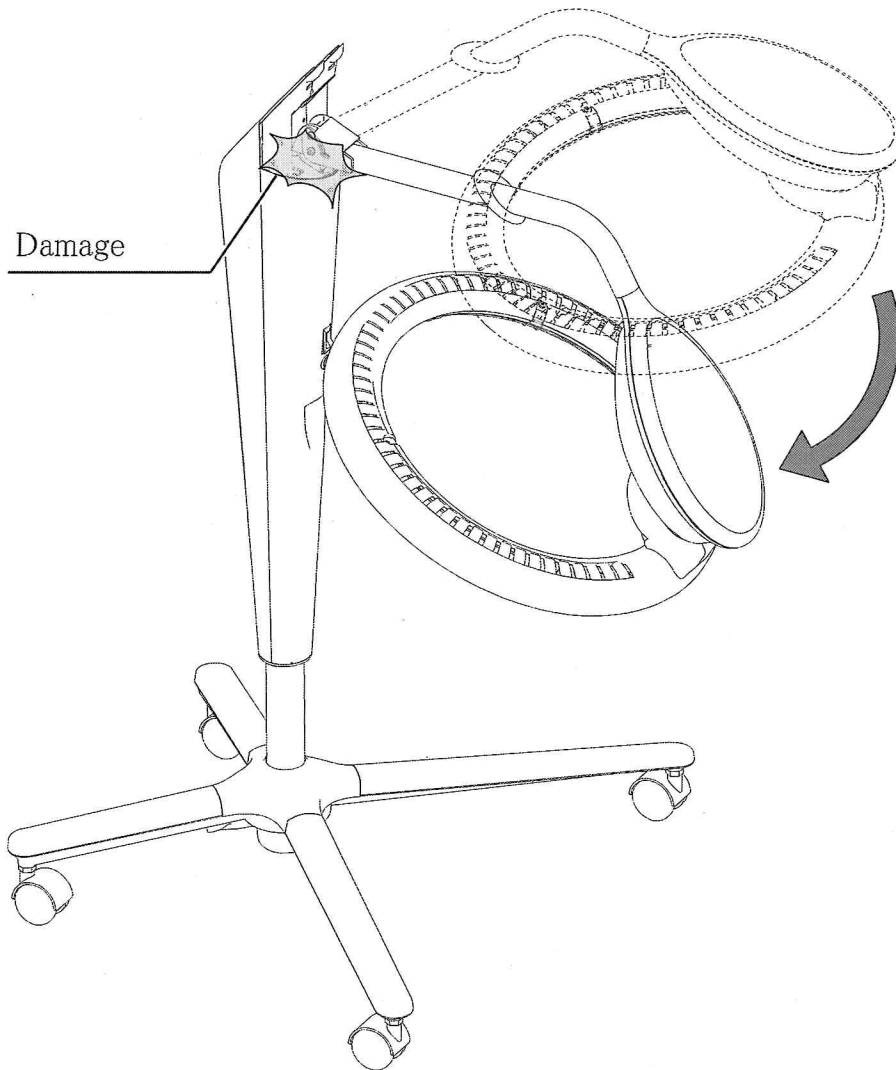

Do not apply pressure onto the shaft.  
\*Doing so may cause a damage of the product.

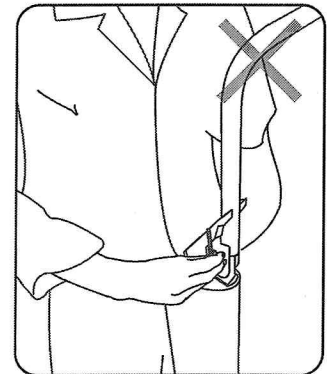
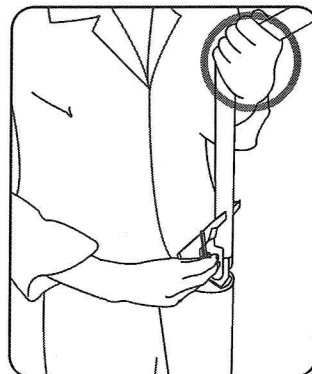
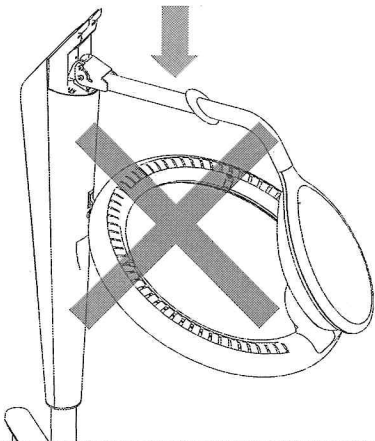

Hold the shaft firmly with your hands throughout the procedure of step. Never release your hands from the shaft until you complete tightening the screws.

• Raising and fixing the shaft.

Loosen the screws on the shaft with the L-shaped wrench, raise the shaft up, and tighten with the lock screw.

\*Never release your hands from the shaft until you complete this procedure.

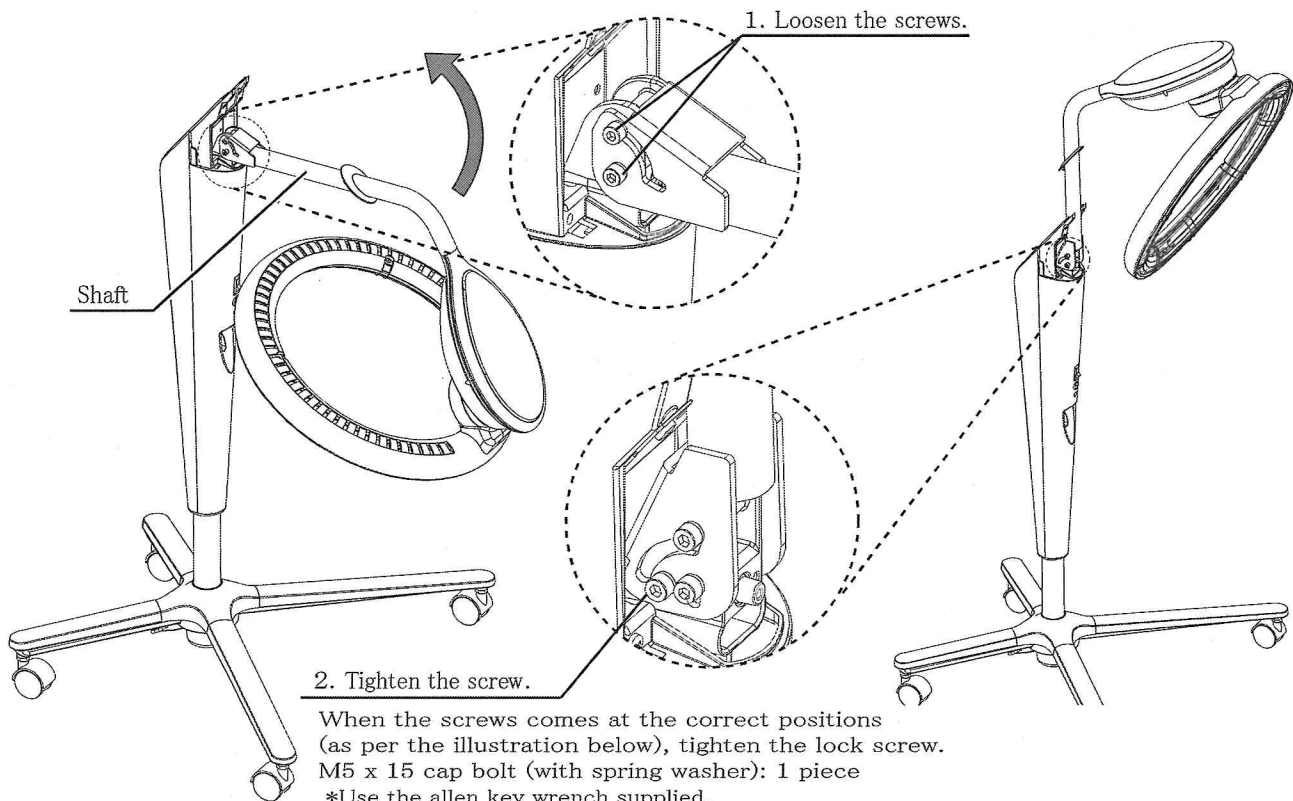

When the screws comes at the correct positions (as per the illustration below), tighten the lock screw.  
 M5 x 15 cap bolt (with spring washer): 1 piece  
 \*Use the allen key wrench supplied.

Hole for the lock screw

This screw prevents the shaft from falling when the screws that fixes the shaft becomes loose.

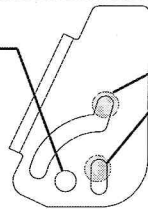

Correct screw positions

Check that the screws are in the correct positions when the shaft is raised.

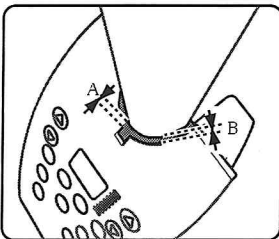

Appropriate Shaft Position

\*The distances A and B should be almost the same.



CAUTION

If A and B are not in the same distance, you will not be able to install the pipe cover correctly.

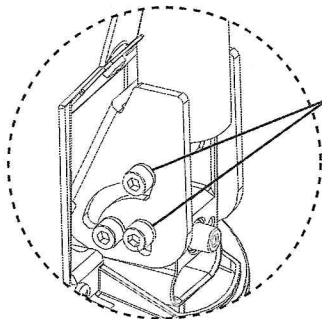

3. Tighten the screws.

Tighten the lower screw first, and then tighten the upper screw .

\*The shaft must be secured tightly since insufficient tightening may cause the unit to rattle.



CAUTION

If the lock screw is not tightened, the shaft may lift from the friction, resulting in tumbling of the product.

- Installing the guide bar.

Insert the guide bar into the main unit and secure it with the two supplied screws.

\*Use the Phillips-head screwdriver.

M4 x 12 binding-head screw : 2 pieces

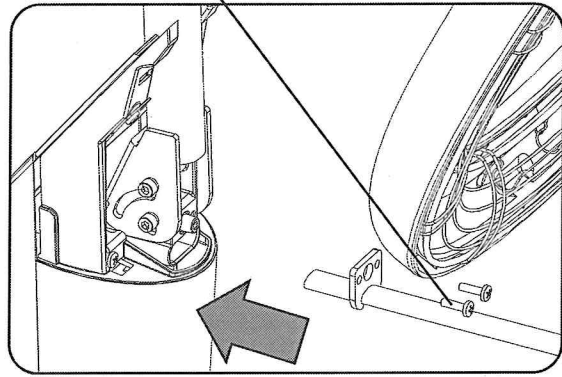
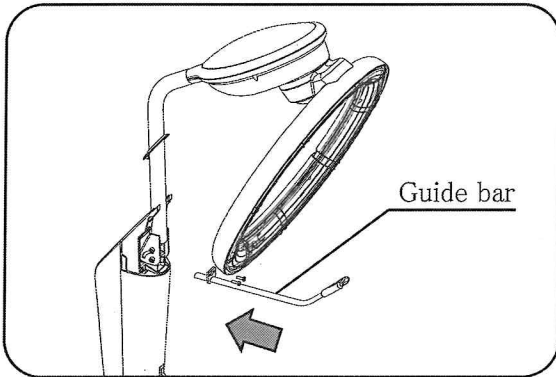

Specification w/o Fan

- Installing the upper main unit cover.

Set the upper main unit cover.

\*Pay attention to the position of the latches.

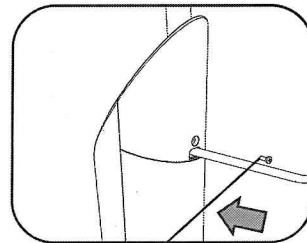
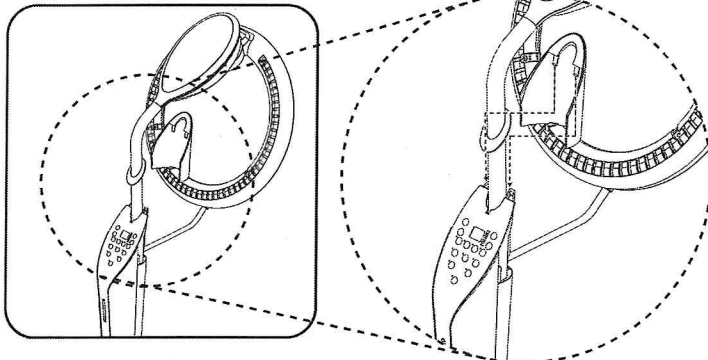

M4 x 12 (black) binding-head screw : 1 piece

Fix the cover at one point with the supplied screw.  
\*Use the Phillips-head screwdriver.

Specification w/ Fan

- Installing the upper main unit cover (with Fan).



CAUTION

Make sure that the lead wire is not caught when installing the upper main unit cover. Neglecting this caution may cause damage to the product such as breaking of wire.

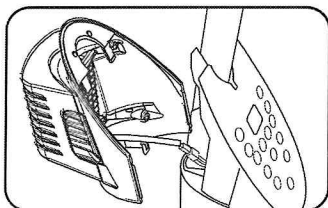

Connect the connector.

\*Lead wire should not get caught.

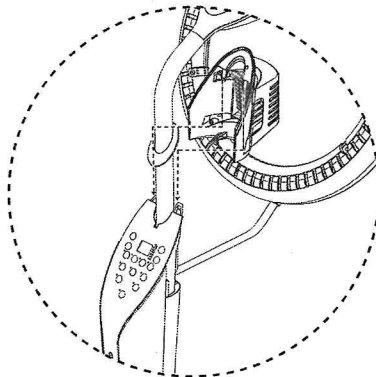

Set the upper main unit cover.

\*Pay attention to the positions of the latches.

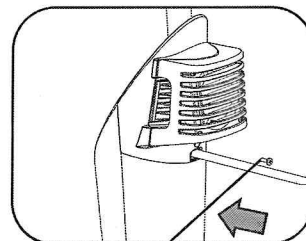

(Black) Binding-head screw M4 x 12: 1 piece

Fix the cover at one point with the supplied screw.

\*Use the Phillips-head screwdriver.



- Installing the pipe cover.

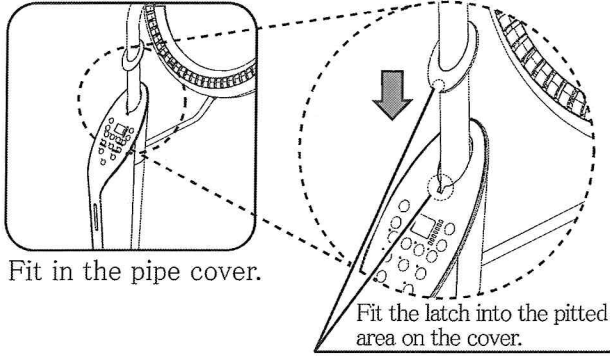

Fit in the pipe cover.

Fit the latch into the pitted area on the cover.

\*Insert the latch provided at the back of the pipe cover into the pitted area on the main unit cover.

### Information

If the shaft is fixed in an inclined position at process step, the pipe cover may not install correctly. If this is the case, adjust the fixing position of the shaft.

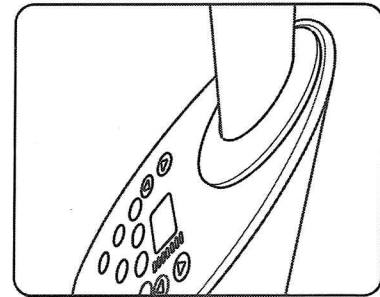

Correctly Installed Pipe Cover

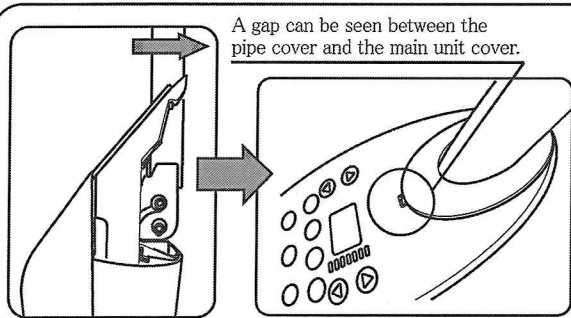

A gap can be seen between the pipe cover and the main unit cover.

Above illustration shows a shaft inclined forward.

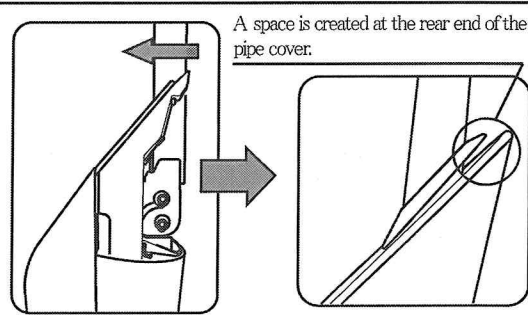

A space is created at the rear end of the pipe cover.

Above illustration shows a shaft inclined backward

- Attaching the power cord.

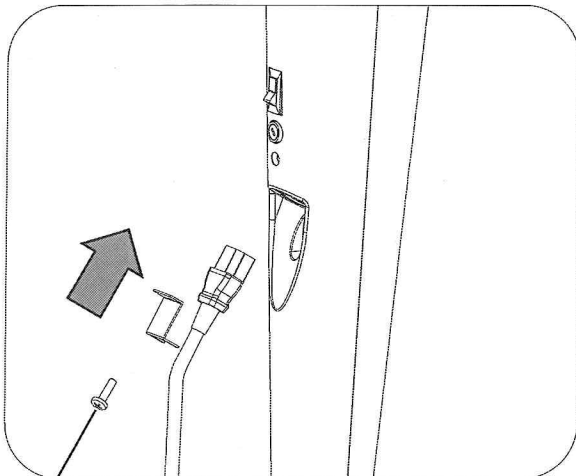

M3 x 15 pan-head screw  
(with flat washer, spring washer): 1 piece

Fix the cord at the power cord stopper at one point with the supplied screw.

\*Use the Phillips-head screwdriver.

- Completion.

\*Be sure to check the operation.

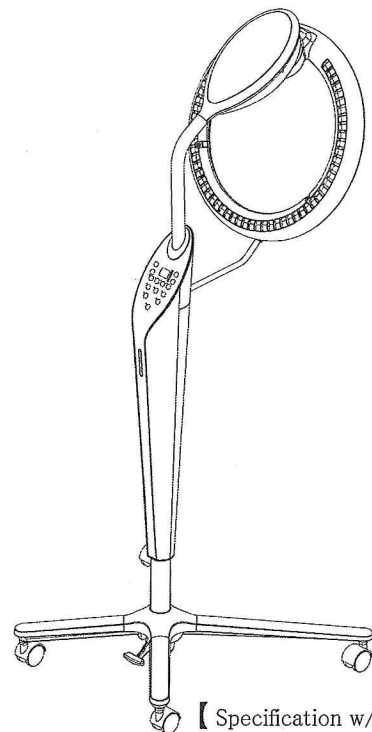

【 Specification w/o Fan 】

## Checking of Operations

### 【Control Panel】

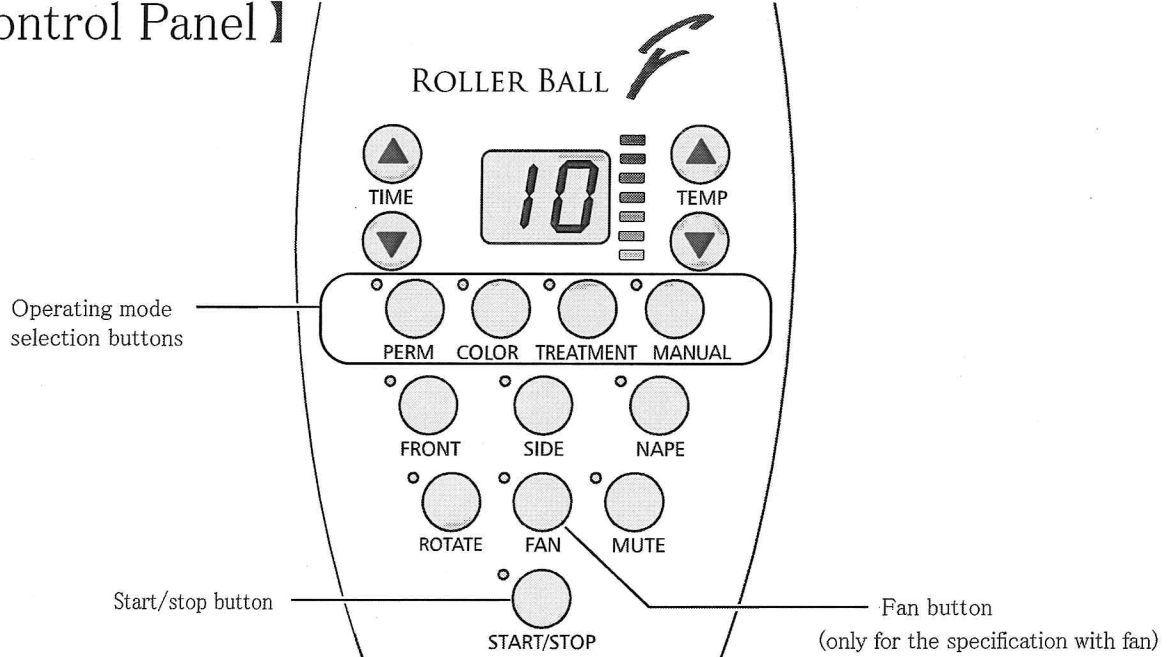

### 【Process】

After completion of the installation, check the following No. ①~③.

\*③ is only for the specification with Fan.

#### ① Check the initial status

- Confirm that all lamps illuminate for one second after turning on the power switch.  
Then only the operating mode lamps (4 lamps) will blink.

#### ② Check the operation

- Press the MANUAL button.  
→ Press Start/Stop button.  
Confirm that the ring rotates and heater works properly  
Pilot lamp (blue) blinks.  
< \*CAUTION >  
Heater starts glowing after the ring rotates approx. 360 degrees.

#### ③ Check the operation of fan (only for specification with fan)

- While doing the check No. (ring is rotating), press the FAN button once.  
\*After pressing the FAN button, fan starts rotating and the lamp of the FAN button illuminates.

After confirming the above, the installation is completed.