

### CARE AND MAINTENANCE GUIDE

- Thermalfused and High Pressure Laminate Surfaces
- Vinyl Upholstery Fabrics
- Cushion Floor Mats
- Hydraulic Bases
- Dryers

**DO NOT DISCARD!**

**IMPORTANT  
INSTRUCTIONS  
FOR CARE AND  
MAINTENANCE.**

**KEEP THIS BOOKLET FOR  
FUTURE REFERENCE.**

### CARE AND CLEANING OF HIGH PRESSURE LAMINATE SURFACES

#### 1. General Cleaning:

Clean the high pressure laminate surfaces of your Belvedere casegoods with a **NON-ABRASIVE** cleanser. Use a soft cloth. Be sure and rinse well with plain water as a final step.

**YOU MAY SAFELY USE:**  
Formula 409®  
Dow Tub and Tile Cleaner®  
Mr. Clean®

#### 2. Furniture Polish:

You may wish to apply a furniture polish to your cabinets. We suggest using a polish formulated specifically for high pressure laminates. These products generally make the surfaces shinier.

**IMPORTANT:** Although thermalfused and high pressure laminate surfaces are among the most durable finishes available for cabinetry, some precautions should be observed:

1. Use of abrasive cleansers will, over time, dull the finish.
2. Avoid striking the laminate with sharp edged objects which can scratch the finish. Protect the laminate from heavy objects which can dent or crush the surface.
3. Avoid placing objects with rough bottom surfaces on the laminate. If necessary, use a pad or coaster under vases or decorative items.
4. Exercise extra care with gloss laminates. Although durable, Gloss laminates will show scratches and abrasions more readily than Matte laminates.
- 5., Be very careful when moving laminated cabinets. Make sure that the bottom edges of laminated panels do not drag or get snagged on carpets. This could cause pieces of the laminate to break off. Also avoid bumping the edges of the laminate. These kinds of damage are very difficult to repair.

**Belvedere USA Corporation**

A Wholly Owned Subsidiary of The Wella Corporation  
One Belvedere Boulevard, Belvedere, Illinois 61008  
Printed in U.S.A. 4001013 Rev. 8-03

---

## CARE AND CLEANING FOR VINYL UPHOLSTERY

The following care and cleaning instructions can be used for almost all of the vinyl fabrics currently used in the salon industry. The vinyl fabrics used are supplied by several manufacturers. Because of the nature of vinyls and the way they are made, these guidelines are applicable to all.

### NORMAL DAY-TO-DAY SOIL:

Normal day-to-day soil can be removed with mild detergent in a warm water solution. Any dish washing liquid will work. 409® or Fantastic® cleansers can be used for tougher soils. Use a soft bristle brush and/or a soft cloth. Be sure to rinse well with plain water as a final step.

### PERM SOLUTION DAMAGE:

There is little that can be done to alleviate perm solution damage if it has been in contact with the vinyl for a significant time. It is a chemical reaction that has altered the vinyl wherever it has come in contact. Whether acidic or basic, most perm solutions are weak. Little or no damage should occur if these spills are wiped up immediately. Again, rinse with water to dilute any residue.

### STAINS:

Stains from ink pens, marker pens, lipstick, grease, spray paint, coffee, blood, oils, etc., can generally be lumped into one category. To clean these, immediately wipe up the spill with an absorbent cloth. Then use the above steps for normal day-to-day soils. If the stain is still present, you can try either rubbing alcohol or naphtha. Each can be obtained at your local hardware store.

Stains from hair colors and dyes are extremely difficult to remove, even if spills are wiped up instantly. Follow the same steps above for cleaning general soils and then again using naphtha for the second cleaning. For the third and final step, apply a 20% by volume creme peroxide and let it sit for as long as 24 hours. There are few if any types of vinyls that can totally resist the staining from hair colors. This is by far the toughest stain to deal with.

### OTHER SITUATIONS:

For other cleaning problems, call Belvedere. Our technicians will work with you to find a remedy for your problem.

If your chairs were built with C.O.M. (customer's own material) upholstery, please contact the fabric manufacturer to obtain their specific cleaning instructions. Belvedere warranties do not apply to C.O.M. materials.

### IMPORTANT NOTE:

Using the above techniques DOES NOT guarantee that you will be able to totally remove all soils or stains from your upholstery. However, these are the best-known methods for dealing with tough stains.

Be aware that the use of cleaners tends to degrade vinyl fabrics, and can make them brittle. The stronger the cleaner or solvent, the more quickly the vinyl degrades. This takes place over a period of time.

---

---

## CARE AND CLEANING FOR PORCELAIN ENAMEL SHAMPOO BOWLS

### 1. General Cleaning:

Always clean your Belvedere Porcelain Enamel Shampoo Bowl with a NON ABRASIVE cleanser. Use a soft cloth. Be sure to rinse well with plain water as a final step.

YOU MAY SAFELY USE:  
Formula 409®  
Dow Tub and Tile Cleaner®  
Mr. Clean®

### 2. Finish Protection:

Protect the finish of your Belvedere Porcelain Enamel Shampoo Bowl by applying a high-quality paste wax once a month. This will help maintain the lustrous finish.

**IMPORTANT:** Use of abrasive cleansers will dull the porcelain enamel finish. Over time, this could cause the finish to become more difficult to clean.

## CARE AND CLEANING FOR ACRYLIC SHAMPOO BOWLS

### 1. General Cleaning:

Always clean your Belvedere Acrylic Shampoo Bowl with NON ABRASIVE soap and water. Review the label instructions before applying any cleaner to the acrylic surface. Avoid harsh chemicals and disinfectants. Use a soft cloth. Rinse well with plain water.

YOU MAY SAFELY USE:  
Formula 409®  
Windex®  
Mr. Clean®  
Glass Plus®

DO NOT USE:  
Lysol Disinfectant Spray®  
Dow Disinfectant Bathroom Cleaner®  
Pinesol®  
Whitecap®  
Lestoil®

### 2. Light Scratches, Abrasions, Gloss:

Light scratches and abrasions may be removed, and original gloss restored using the following:

Plastic cleaners (eliminate very light scratches and restore gloss):

- Novus® Plastic Polish
- Permatex® Plastic Cleaner #430D
- Mirror Glaze® Professional Formula #17

Automotive cleaner waxes (eliminate very light scratches and provide protection):

- J-Wax® or Kit® Automotive Cleaner Wax

Polishing compounds (eliminate moderate scratches; follow manufacturer's instructions):

- Dupont® or Turtlewax® White Polish Automotive Polishing Compound

Note: Avoid using excess pressure when polishing with these compounds.

## DO NOT PLACE NAIL CARE PRODUCTS, KETONES, ESTERS OR AROMATIC HYDROCARBONS ON YOUR ACRYLIC BOWL.

- Prolonged exposure to these chemicals may discolor or damage the acrylic finish.
  - Wipe off any chemicals immediately!
  - Using the above techniques DOES NOT guarantee that you will be able to totally remove all soils or stains from your shampoo bowl.
  - For other cleaning problems, call Belvedere. Our technicians will work with you to find a solution.
-

---

## CLEANING AND POLISHING/CARE FOR ANTI-FATIGUE FLOOR MATS

1. To maintain appearance, damp mop or wipe surface as needed with cloth dampened with COLD water. This removes surface dust and grit.
2. When Step 1 no longer restores appearance, clean surface with a standard liquid ALL-PURPOSE cleaner, rinse, and let dry. If you prefer a high gloss luster, apply one coat of an oil-based soap such as Murphy's Oil Soap, following directions on the label. Although polishing is not required, a brisk rubbing with a soft cloth will result in a brighter and long-lasting finish.

### DO NOT USE FULL STRENGTH INDUSTRIAL CLEANERS CONTAINING SOLVENTS OR ABRASIVE CLEANSERS.

3. When the floor is scrubbed or mopped, it is recommended that mats be removed prior to cleaning the floor and repositioned after the floor is completely dry. This practice will eliminate the chance of floor staining, as well as potential damage to the cushion sponge.
4. Too much wax forms an unsightly layer that actually holds dust and dirt and mars appearance. If wax build-up occurs, remove it with one cup of household ammonia and 1/4 cup all-purpose cleaner in 1/2 gallon of COOL water. Be sure to rinse well. Refinish appearance by applying TWO coats of oil-based soap, such as Murphy's Oil Soap. Follow the directions on the label.

**CAUTION: DO NOT FOLD OR LAY MAT WITH FLOORING FACING IN. THIS WILL CAUSE CRACKING. WHEN CLEANING THE FLOOR, REMOVE THE MAT. NEVER PLACE THE MAT ON A WET FLOOR. IF USED ON CARPET, MOISTURE MAY CAUSE STAINING.**

**IMPORTANT: MATS ARE NOT WARRANTED FOR DAMAGE CAUSED BY HIGH HEELS, ELEVATED HEELS, OR SPIKED HEELS. SEE WARRANTY PAGE FOR DETAILS.**

---

## HYDRAULIC BASE BRAKE ADJUSTMENT INSTRUCTIONS

1. Pump the chair to its highest position.
2. Remove the Retaining Screw from the top of the Cap.
3. Slide the Cap up to the top of pump shaft. Tie an old towel or rag around the pump shaft to hold the Cap in place.
4. Be sure that the set screws holding the Pump Bail in place are tight. If they are loose, you will not be able to properly adjust the Brake. Tighten the set screws with an Allen wrench.
5. Adjust the Brake by tightening or loosening the nut.

### NOTE:

Overtightening will make the chair difficult to turn.

Undertightening will allow the chair to turn too easily when the Brake is set.

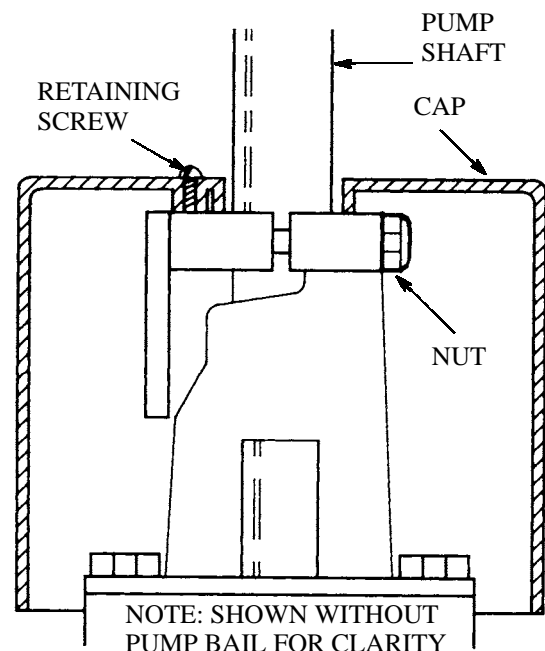

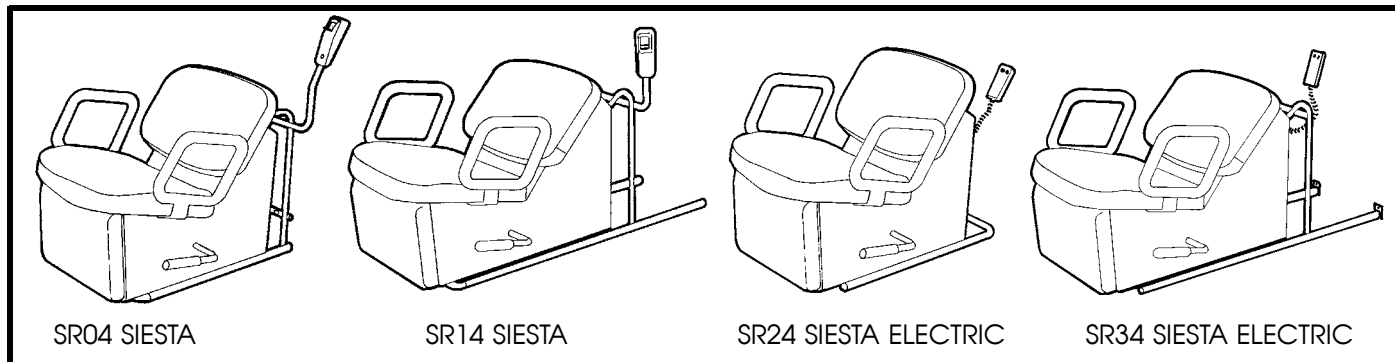

SR04 SIESTA

SR14 SIESTA

SR24 SIESTA ELECTRIC

SR34 SIESTA ELECTRIC

### WHY SIESTA?

Siesta Backwash and Conventional

Congratulations. You have purchased the most advanced and comfortable shampoo seating system available. The Siesta is ergonomically designed. The seat adjusts at an angle to maintain proper alignment between the bowl and the client. This provides a consistent level of comfort throughout the adjustment range. The fixed seat cushion-to-backrest angle provides a feeling of security as well.

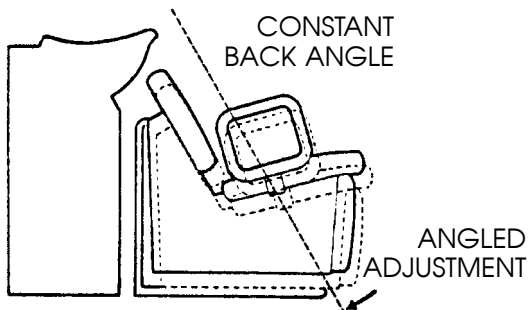

The Siesta chair adjusts to accommodate over 90% of all salon clients without cumbersome pumps. Siesta's constant back angle positions the client properly, regardless of the seat height.

### CARE AND CLEANING

Your Siesta chair requires minimal maintenance. Clean the vinyl fabric with soap and water. Avoid harsh cleaners or solvents. Do not attempt to service or disassemble the gas-spring lift mechanism. Call your service technician.

### USING SIESTA (WITH PNEUMATIC LIFT)

Release the height adjustment control and allow the chair to rise to the highest position before seating the client.

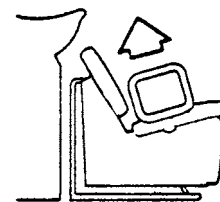

**Note:** The chair rises only when unoccupied. With the chair all the way up, seat the client.

You or the client may raise the legrest. Grasp the handle and pull back.

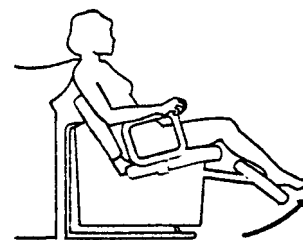

**Caution:** The legrest is spring-loaded.

**Note:** Clients wearing dresses may want a towel or cape over their legs.

Now pull the height-control lever gently until the client is properly positioned. The chair will lower only with a person in it. If you go too far, have the client stand and start over. Heavier clients will lower the Siesta chair slightly faster than petite clients. Clients may push the handle down to lower the legrest to exit.

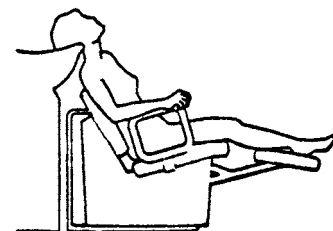

**Belvedere USA Corporation**

A wholly owned subsidiary of The Wella Corporation  
One Belvedere Boulevard, Belvidere, Illinois 61008  
Printed in U.S.A. E.C.O. 6065 4000831 Rev. 1-01

## USING ELECTRIC SIESTA

The SR24 electric siesta comes with a ten foot power cord. The unit must be plugged into a GCFI (Ground Fault Circuit Interrupter) circuit or outlet. The GCFI should be installed by a qualified electrician. The outlet may be located on the wall or in the floor according to local electrical codes. Electrical requirements: 115V, 100 watts.

You or the client may raise the legrest. Grasp the handle and pull back.

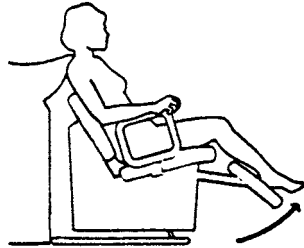

### NOTE:

Clients wearing dresses may want a towel or cape over their legs.

Push the up or down button on the handset until the client is properly positioned. Clients may push the handle down to lower the legrest to exit.

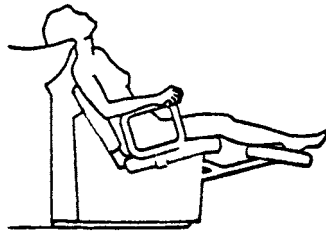

## SIESTA CHAIR INSTALLATION

1. Remove the Siesta chair from the carton.  
**CAUTION!** To avoid potential damage to the upholstery, do not use a knife to open the carton.

2. Carefully remove the protective packing from the control.

Backwash Units:

3. Place the rearmost bottom tube of the Siesta's frame into the "J"-shaped brackets on the front of the Backwash cabinet.

Conventional Units:

4. Place the Siesta in front of the Shampoo bowl. The Mounting Plates at the back of the Siesta frame should be against the shampoo bulkhead or wall. Be sure the Siesta chair is centered under the bowl.
5. Drive wood screws (obtain locally) through the holes in the mounting plates and into the bulkhead or wall.

Electric Siesta:

6. You will find a self-adhesive Hook-and-Loop strip on the back of the lift control. This provides a place to store the control when not in use. To apply, just remove the protective liner from the Hook-and-Loop strip, and press it in the desired location.

Suggestion: For Backwash systems, apply the strip to the slanted acrylic cabinet top, on the opposite side of the bowl from the shampoo well.

For other systems, apply the strip in a location that is easy to reach.