

SHAMPOO UNIT

YUME

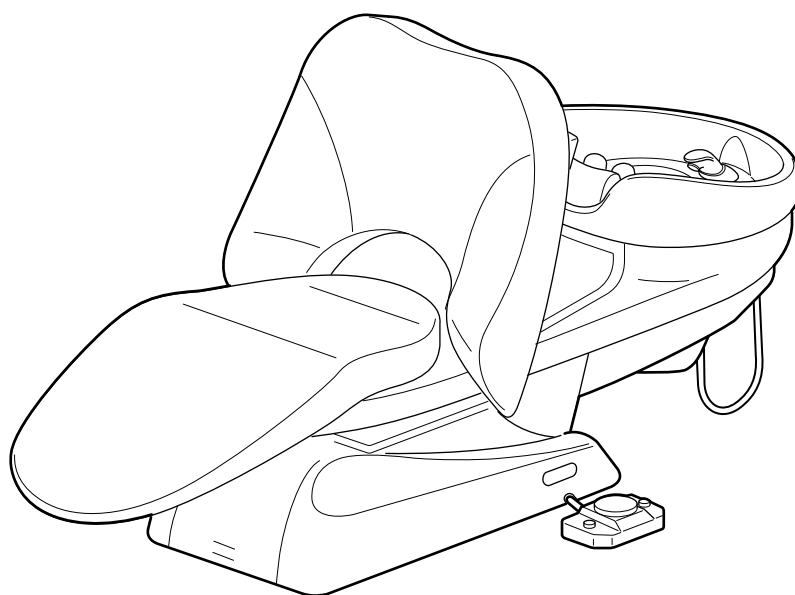

INSTALLATION INSTRUCTIONS

IMPORTANT

This manual provides information and instructions for YUME SHAMPOO UNIT. The instructions contained in this booklet should be thoroughly read and understood before attempting to install the equipment.

After the installation is completed, file this manual and refer back to it for future maintenance.

 **TAKARA
BELMONT**

IE00G8A0

TABLE OF CONTENTS

INSTALLATION INSTRUCTIONS

1. Overall View and Major Components.....	1
2. Dimension & Specifications.....	2
3. Plumbing Layout.....	3
4. Contents of Unpacked Products	4
5. Installation Instruction.....	5
5-1. Preparations for Installations	5
5-2. Installation of the Carriage Jig	5
5-3. Marking for unit fixing position	6
5-4. Fix the Moistureproof sheet and packing.....	6
5-5. Installation of unit	6
5-6. Drain Pipe Connection	8
5-7. Water and Hot Water Supply Line Connection	8
5-8. Unit Power Supply Line.....	9
5-9. Installation of Base Cover.....	9
5-10. Attach the backrest and seat cushion	10
5-11. Attach the Neck Cushion.....	11
5-12. Attach the Head Pillow	11

1. Overall View and Major Components

■ Body

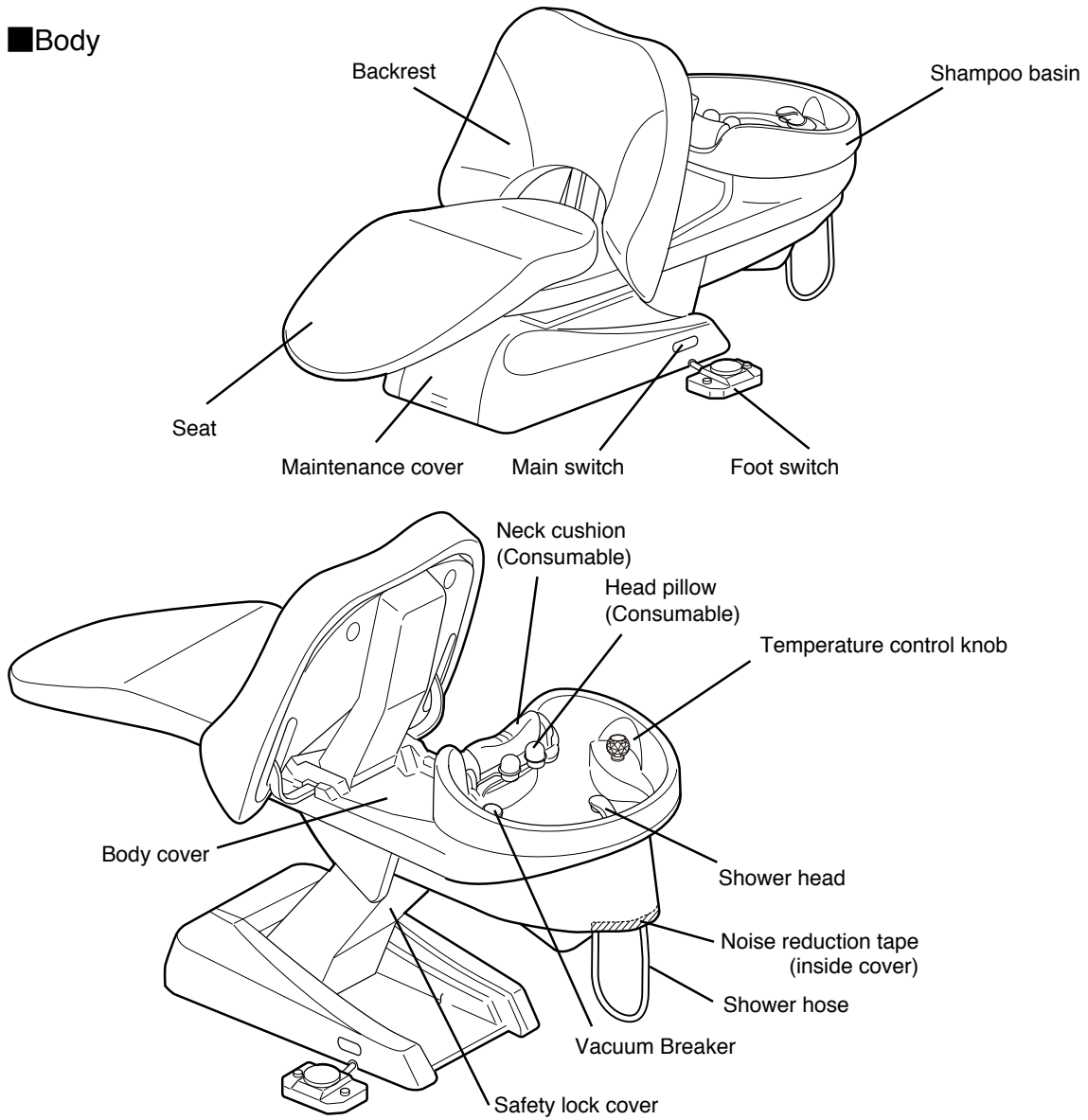

■ Foot switch

EX-YML : left side foot switch

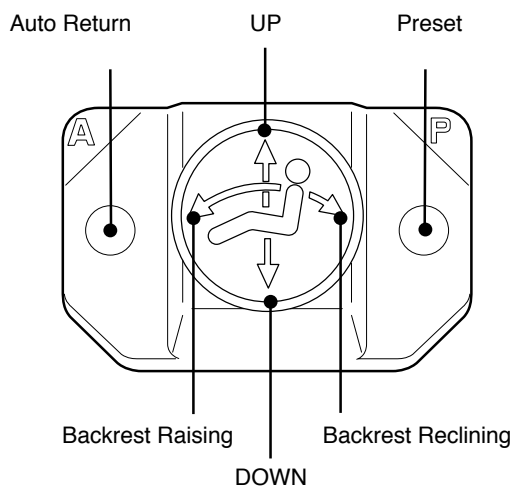

EX-YMR : right side foot switch

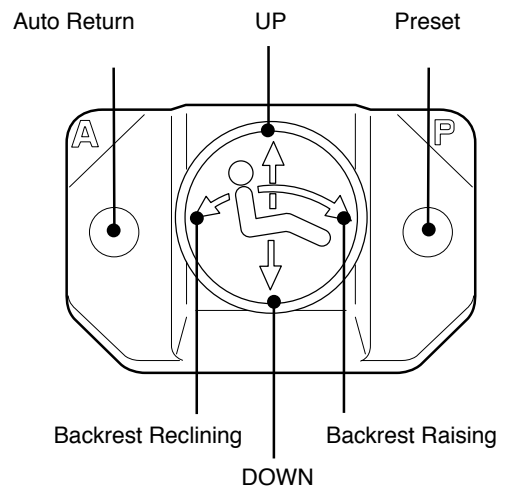

4. Contents of Unpacked Product

- YUME Main Body

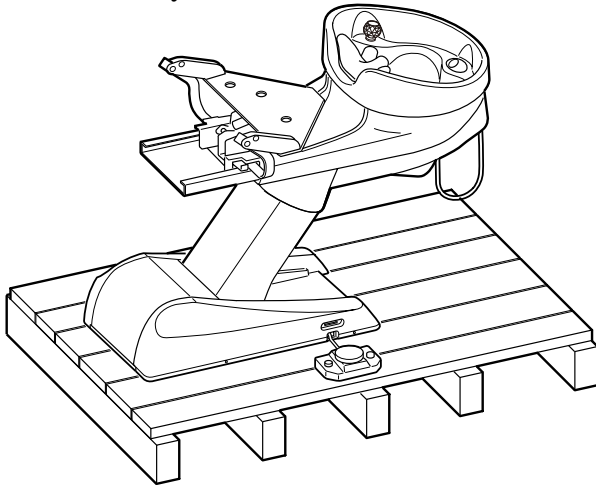

- Carriage Jig

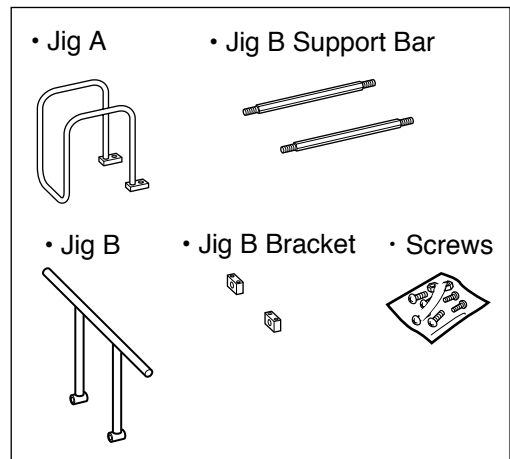

- Seat and Backrest set

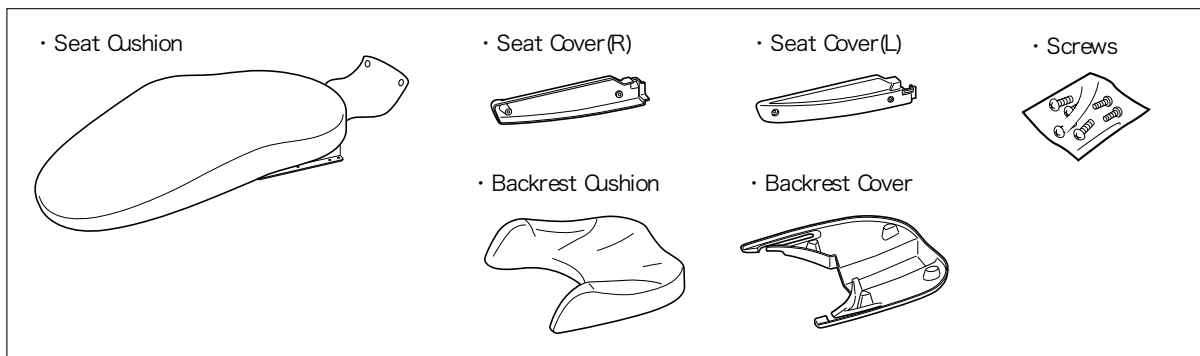

- Neck Cushion



- Head Pillow



- Drain Cap



- Hair Catcher



- Floor Bolts
M8x70 Anchor Bolt x8
M8x65 Hex Head Tap Bolt x8
Flat Washer x8



- Moistureproof Sheet

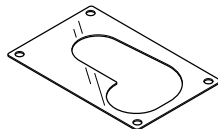

- Moistureproof Packing (Sponge)

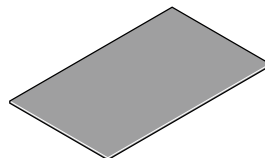

- Noise Reduction Tape

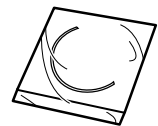

- Water Stop Valve

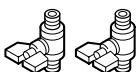

- Flexible Pipe



- Drain Hose Packing

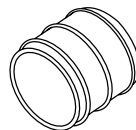

- Drain Hose Clamp

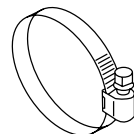

※ Elbow and drain pipe(VU40) are NOT INCLUDED with shipment. Please prepare it beforehand.

5. Installation Instruction

5-1. Preparations for Installations

1. Unpacking

Remove nails from lower part of wooden crate.
Lift up the upper portion of wooden crate.
Chair will be left on the skid.

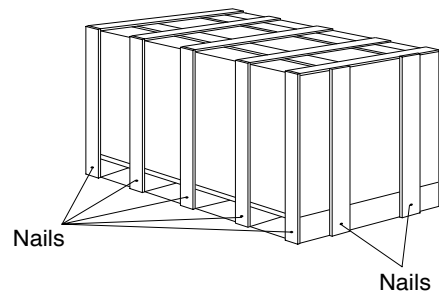

2. Remove the pump cover.

1. Remove the screws and remove maintenance cover, base cover left and right from main body.
2. Remove the oil plug with red tag from oil reservoir.
3. Plug the unit power supply plug in to the suitable power supply outlet.
4. Turn on the main switch located on the left side of base.
5. Keep depressing UP button of foot switch until the seat is lifted up to the end.
6. Turn off the main switch
7. Unplug the unit power plug from power supply outlet.

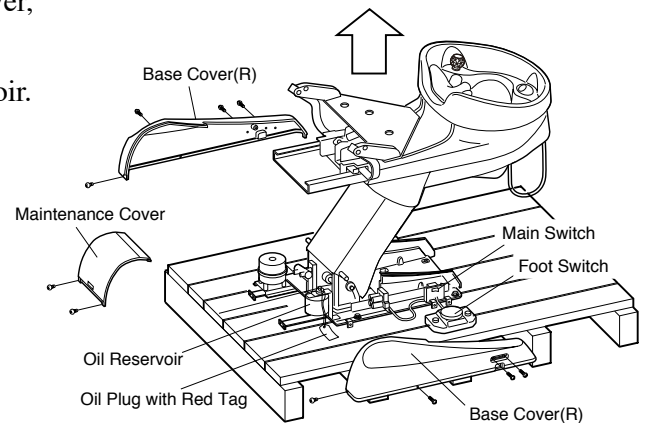

Note : Do not remove the unit from the pallet until the unit fixing position is ready.

5-2. Installation of the Carriage Jig

Holding the Carriage Jig and place it at planned location. Do not carry by holding the body or basin.

1. Fix the Jig A to the base.(M10 x 30)
2. Fix the Jig B bracket to the base.(M10 x 50)
3. Attach the Jig B support bar to the Jig B bracket.
4. Attach the Jig B to the Jig B support bar and tighten the nuts.(M16)

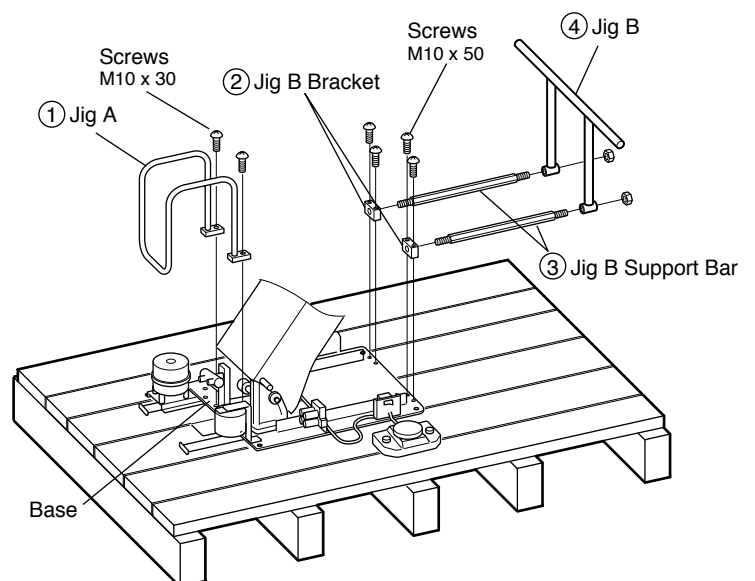

CAUTION

Do not turn on power during installation.

5-3. Marking for unit fixing position

Use supplied full scale template to mark the fixing position on the floor. Check the piping and power outlet position before marking.

1. Put the supplied template on the floor and hold with the tape etc. It should be set to the position of piping and power outlet.
2. The chair fixing position is marked on the floor.
3. Make it holes for marked position. (8.5 mm x 50 mm)
4. Remove the template from the floor.

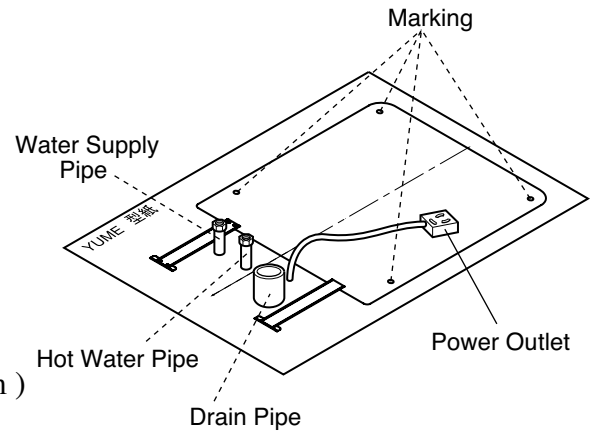

5-4. Fix the Moistureproof sheet and packing

Please obtain the moistureproof sheet and the moistureproof packing to prevent from the main body damaged by the moisture. Deterioration and the breakdown of structural parts and electrical equipments might not be occurred without the installation.

1. Fix the moistureproof sheet on the floor.
 - Plywood Floor : Wood Screw
 - Concrete Floor : Glue
2. Make a cut in the moistureproof packing according to piping position.
3. Peeled off the sheet on the adhesive face side of the moistureproof packing. Passes under the piping and electric code on the moistureproof packing and attach to the floor.
4. Seal a space around the piping and electric code.

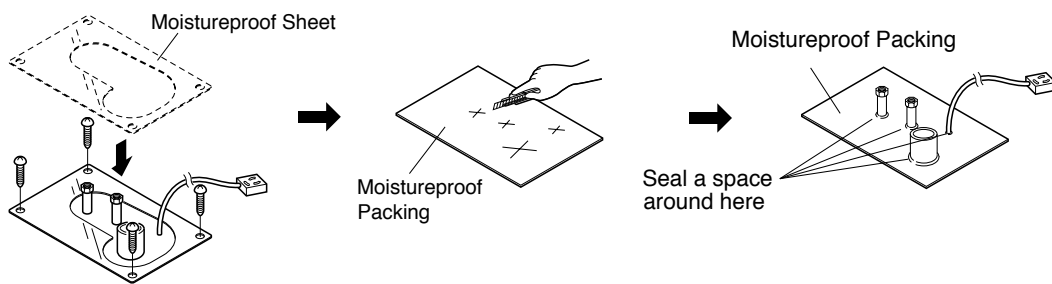

5-5. Installation of unit

1. Remove the four tapping screw(M8 x 60mm) fixing the unit base plate to the pallet.

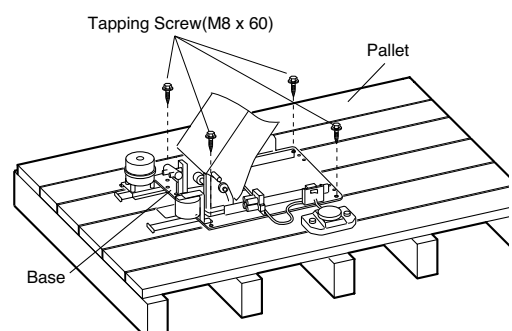

2. Hold the carriage jig and move the main unit to marked position on the floor.
3. Decide the installation position and remove the carriage jig A and B from main unit base.

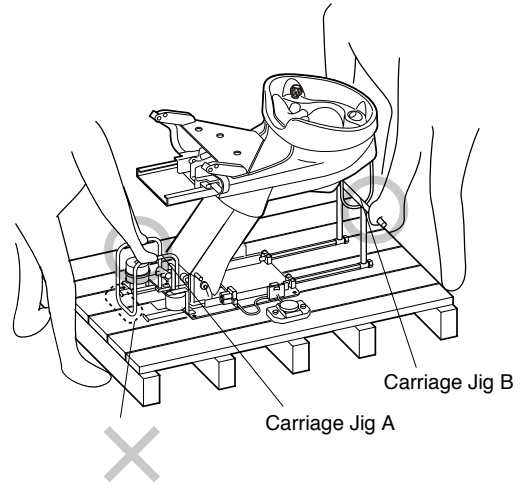

CAUTION

Hold the Jig A and B to lift the unit by 2 workers to move it. Otherwise, breakage may result in.

Do not make scratch or damage the floor while moving the unit. Please use the carriage jig to move it.

4. Fix the main unit with the four screws.
 Plywood Floor : Hex head tapping screw M8 x 65
 Concrete Floor : Anchor bolts M8 x 70
5. When the moistureproof packing is bigger than main unit base, please cut it out.

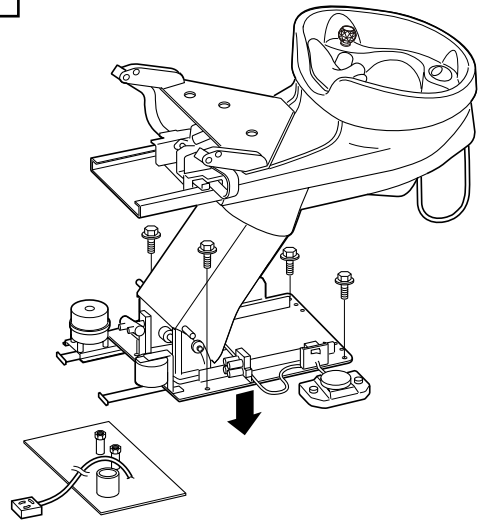

● Construction process of anchor bolts.

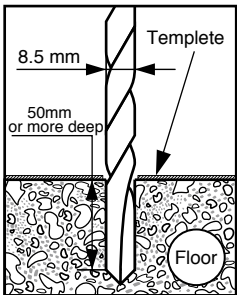

1. Drill the anchor holes of a specific diameter and depth.

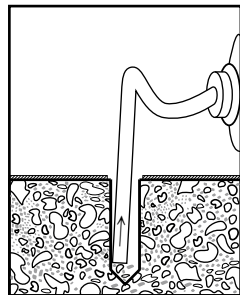

2. Clean each anchor hole thoroughly using a vacuum cleaner, with a narrow nozzle attachment to reach into the hole and remove all debris.

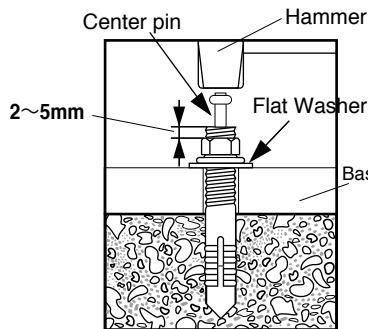

3. Insert the anchor bolt, tapping it lightly with a hammer to seat it. Position the material, and then drive the center pin into the anchor unit it is snug.

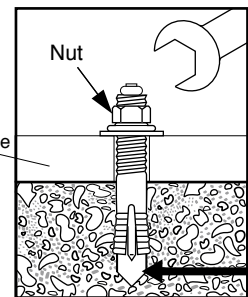

4. Adjust the fastening strength of the nut using a wrench etc.

CAUTION
 If the anchor bolt is tapped with its and contacting the bottom of the hole, the strength will be lowered. Proper clearance must exist between the end of the anchor bolt and the bottom of the hole.

5-6. Drain Pipe Connection

Elbow and drain pipe(VU40) are not included with shipment. Please prepare it beforehand.

1. Insert the elbow to the drain pipe from floor with seals.

CAUTION

The height of drain pipe should be less than 60mm.

CAUTION

Do not tear up the vinyl which is covered the drain hose.

2. Adjust the length of drain pipe(VU40), so that the one end of drain pipe(VU40) may become on the edge of the base, and connect to elbow with seals.
3. Connect the drain hose packing to the drain pipe(VU40).
4. Through the drain hose clamp to the drain hose, and connect the drain hose to the drain hose packing.
 - The drain hose shall be free of dent.
 - Attach the drain hose so as not to be folded.
5. Fasten the screw of the drain hose clamp for drain hose.
 - Tightening too hard may damage the drain hose.
 - Do not tighten too hard.
6. Cover the elbow part with the vinyl.

CAUTION

Make sure all connection is surely fixed.
please confirmed the water does not leak.

5-7. Water and Hot Water Supply Line Connection

1. Install the stop valve to each supply pipe.
2. Bend each flexible pipe to a suitable angle for connection.
3. Connect the each Check Valve to the each stop valve with the flexible pipe.

CAUTION

Check the each connection for leaks.

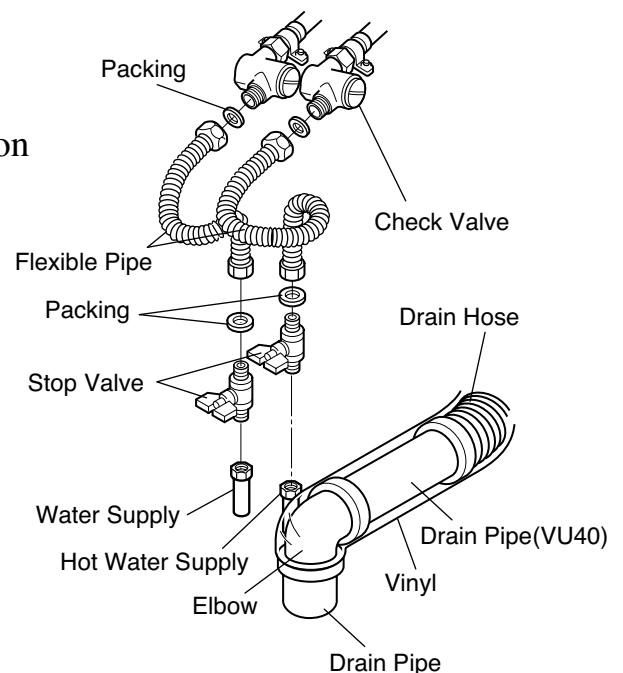
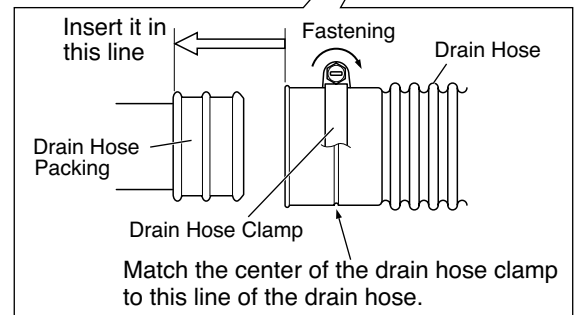
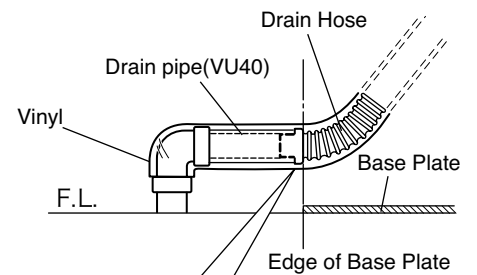
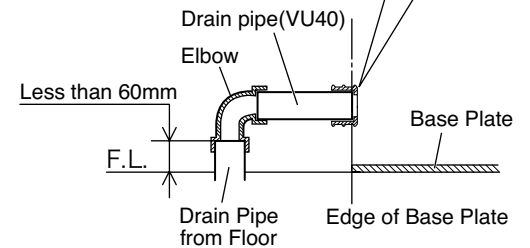
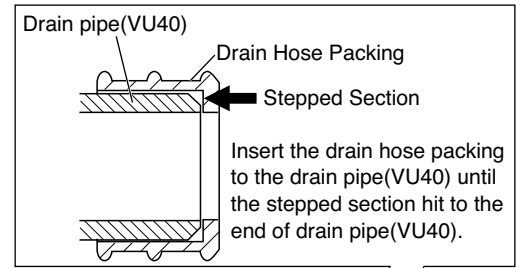

5-8. Unit Power Supply Line

1. Fix the plug on the end of the unit power supply cable.
Plug the unit power supply plug into the suitable power supply outlet.

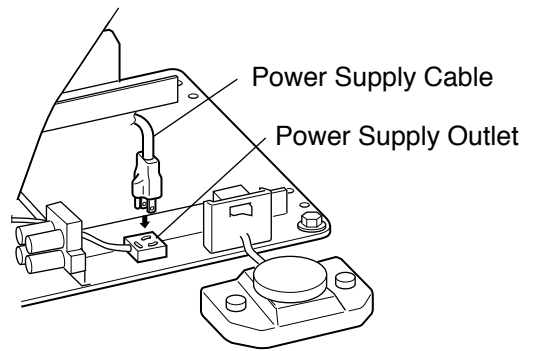

CAUTION

This appliance is equipped with a cord having an equipment-grounding conductor and a grounding plug. The plug must be plugged into an appropriate outlet that is properly installed and grounded in accordance with all local codes and ordinances.

5-9. Installation of Base Cover

1. Remove the oil plug red tag from the oil reservoir.
2. Fix the base cover left & right with screws(M4 x10).

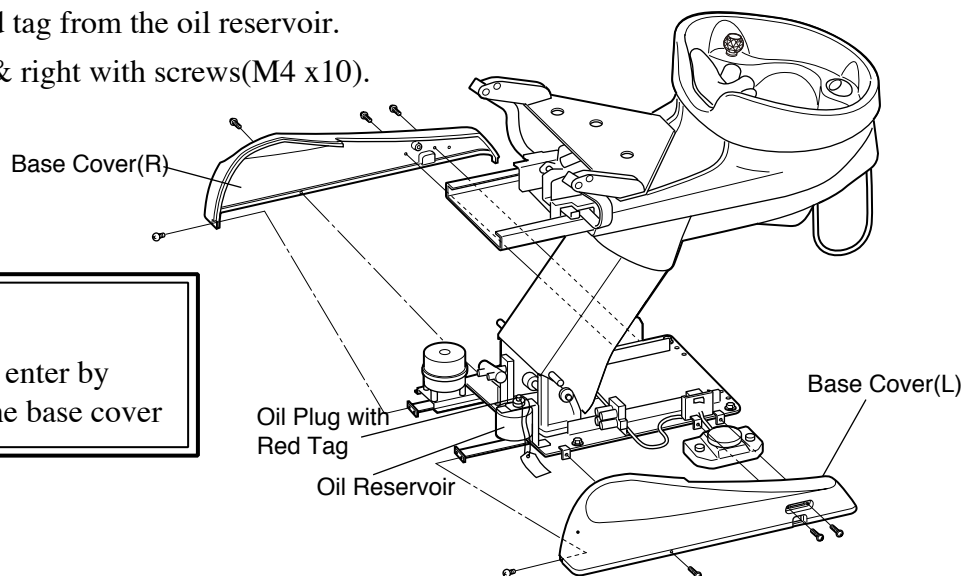

CAUTION

The main switch does not enter by mistake when attaching the base cover

3. Fix the center base cover with screws and plastic washer (M5 x 20).

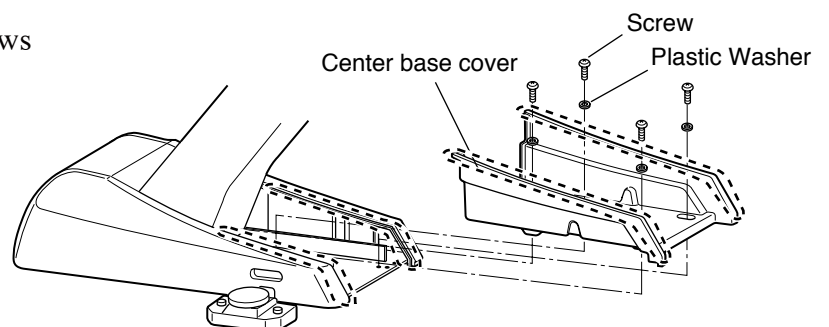

4. Fix the maintenance cover
Attach the maintenance cover to the base cover left & right and fixed with screw(M4 x 10)

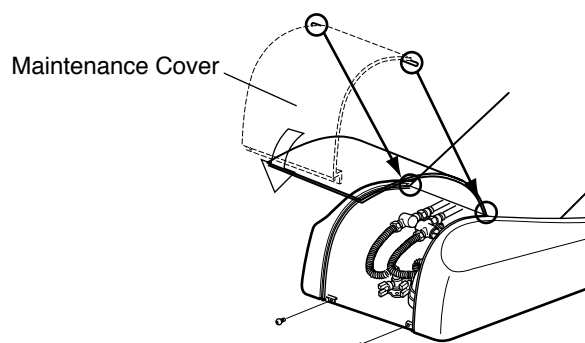

5-10. Attach the backrest and seat cushion

1. Fix the seat cushion with six cap bolts(M5×15)
2. Fix the seat cover L & R with screws.
3. Keep depressing backrest raising button until the backrest frame is raised position.
4. Attach the backrest cushion to the backrest frame and fixed with screws(M6 x 20)

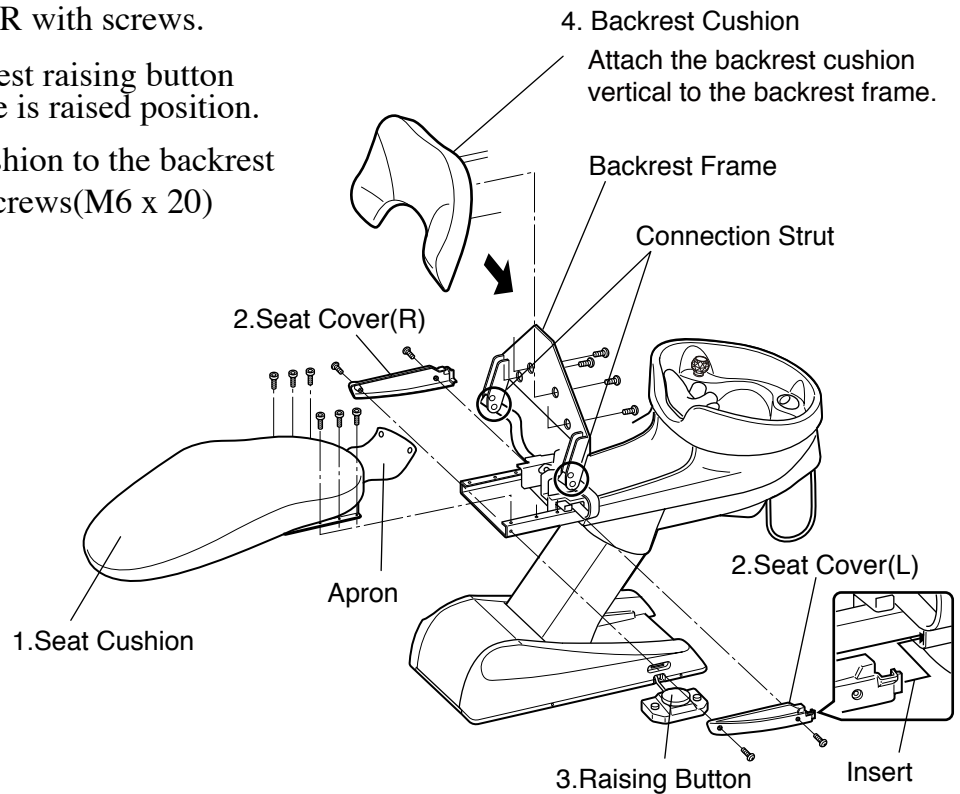

5. The apron from seat cushion is inserted between the backrest cushion and the cylinder, then fixed with two screws(M4 x 18)
6. Attach the backrest cover and fixed with six screws(M4 x 18)

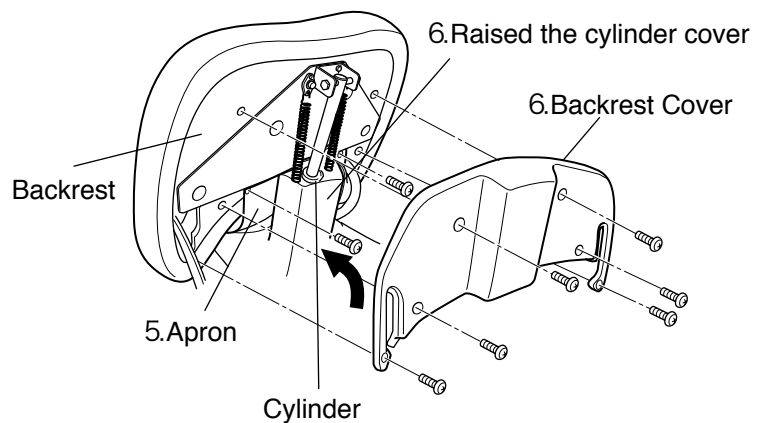

5-11. Attach the Neck Cushion

1. Attach the neck cushion on metal fittings as shown in figure.

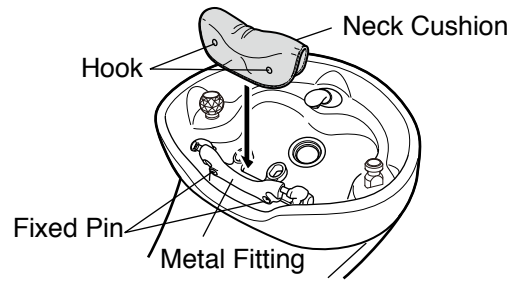

2. Both side hooks of the neck cushion is fixed on a fixed pin.

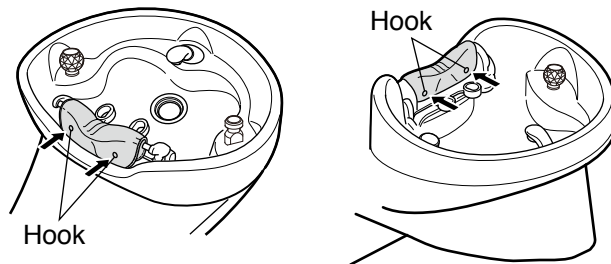

5-12. Attach the Head Pillow

1. Attach the head pillow as shown in figure.

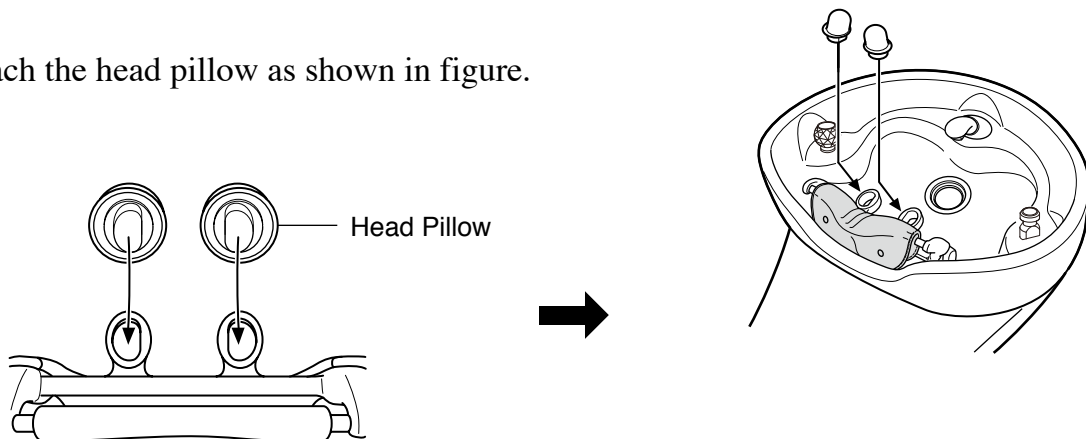

NOTE



TAKARA BELMONT U.S.A., INC.

101 Belmont Dr., Somerset, NJ 08873

TEL. : Toll Free (866) 4 TAKARA (866-482-5272)

TELEFAX : 732-469-9430