

Shampoo Fixtures

VACUUM BREAKER AND HOSE RECEIVER

VACUUM BREAKER AND HOSE RECEIVER INSTALLATION

NOTE: To familiarize yourself with the various components, please read instructions through before starting. Vacuum breakers should not be subjected to continuous pressure for more than twelve (12) hours. Check local plumbing codes for specific mounting-height requirements.

1. Before installing your new Belvedere shampoo bowl, we recommend that you first install the plumbing fixtures to the bowl. For easier installation, place the bowl on its side or back. Attach the fixtures to the bowl according to the instructions packed with each fixture.

TO ATTACH HOSE RECEIVER TO BOWL (STEPS 2 thru 6).

2. To make hose receiver installation easier, complete these steps to cut screw threads in the mounting holes:
 - Take a mounting screw and drive it 2 or 3 turns into one hole.

DO NOT OVERTIGHTEN.

 - Remove the screw.
 - Repeat for all four (4) mounting holes.

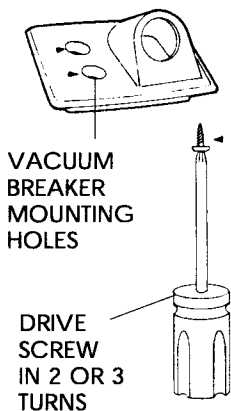
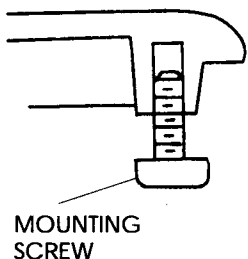

If the bowl is not equipped with a vacuum breaker, proceed to Step 4.

***NOTE:** If you ordered a vacuum breaker, your hose receiver will have two holes for mounting the vacuum breaker.

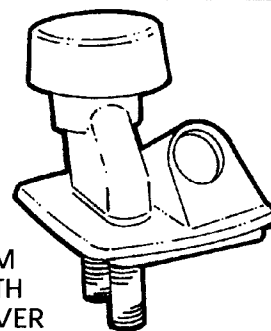

3. Remove the two (2) hex-nuts and washers from the vacuum breaker pipes. Place the vacuum breaker pipes through the holes in the hose receiver as shown. Secure the vacuum breaker to the hose receiver with the washers and hex-nuts. **DO NOT OVERTIGHTEN.**

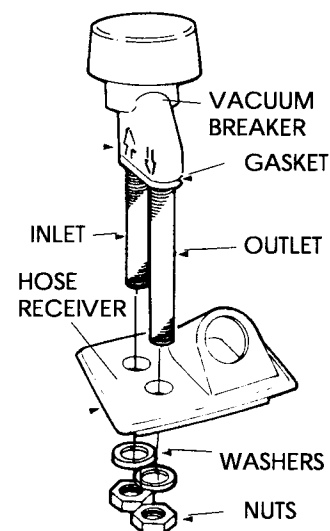

NOTE: Install the vacuum breaker as shown. If the vacuum breaker is installed backwards, it will interfere with the Whiz Spray.

4. Place the gasket over the flange on the bottom of the hose receiver.

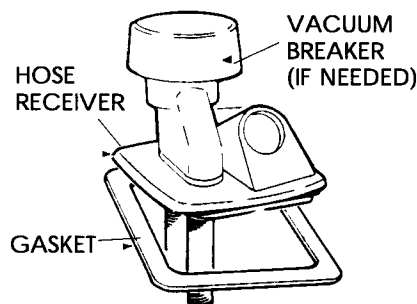

Belvedere USA Corporation

A wholly owned subsidiary of The Wella Corporation
One Belvedere Boulevard, Belvidere, Illinois 61008
Printed in U.S.A. 4000788 Rev. 1-01

belvedere®

5. Place the hose receiver in the bowl with the large hole in the dome facing the front of the bowl. Install the mounting bracket on the bottom side of the bowl with four (4) embossed corners facing upward, against the bottom of the bowl. Secure with four (4) mounting screws. **DO NOT OVERTIGHTEN.**

NOTE:

On the following bowls, install the bracket with the embossed corners facing down, away from the bowl: 400, 4000, 8200, 8500, and 8501.

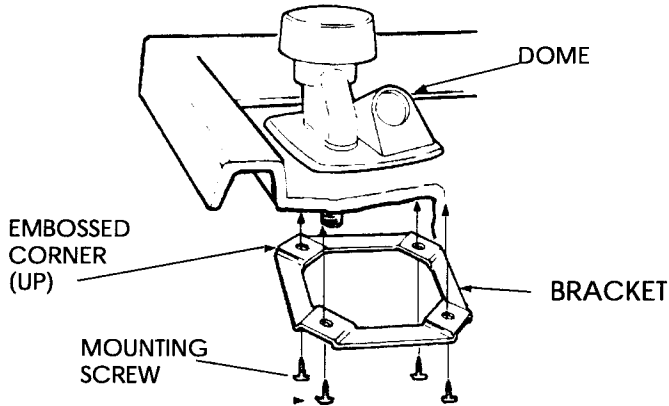

6. If your bowl *is not* equipped with a vacuum breaker attach the WhizRSpray hose connector to the fixture tailpiece.

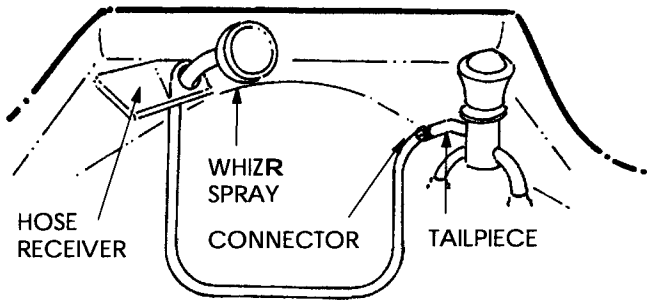

If your bowl *is* equipped with a vacuum breaker, connect one end of the fixture hose to the inlet side of the vacuum breaker. Connect the other end to the fixture tailpiece. Attach the WhizRSpray hose connector to the vacuum breaker outlet.

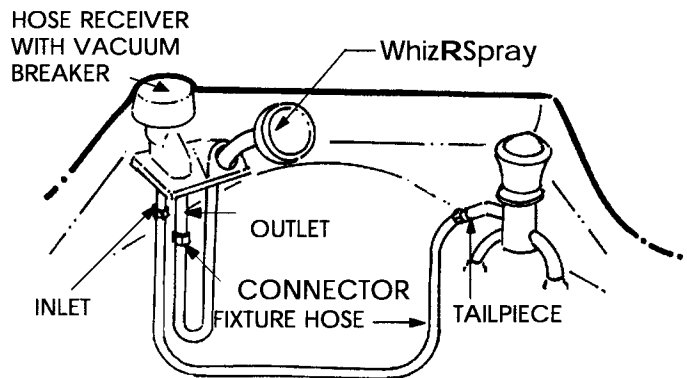

REPLACEMENT PARTS

403 and 403L Vacuum Breaker

Bagged Assembly Number

Description

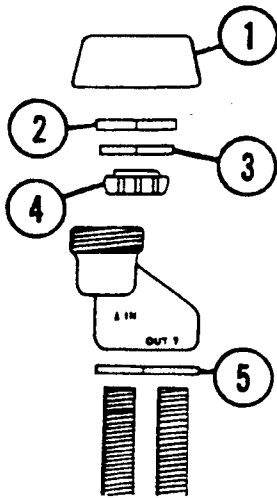

5001774	_____	1 Cap
5001228	_____	2 Retainer 3 Seat Washer 4 Float
5001660	_____	5 Rubber gasket

Instructions: Turn cap counterclockwise to remove. Lift up on retainer, washer and float to remove.